

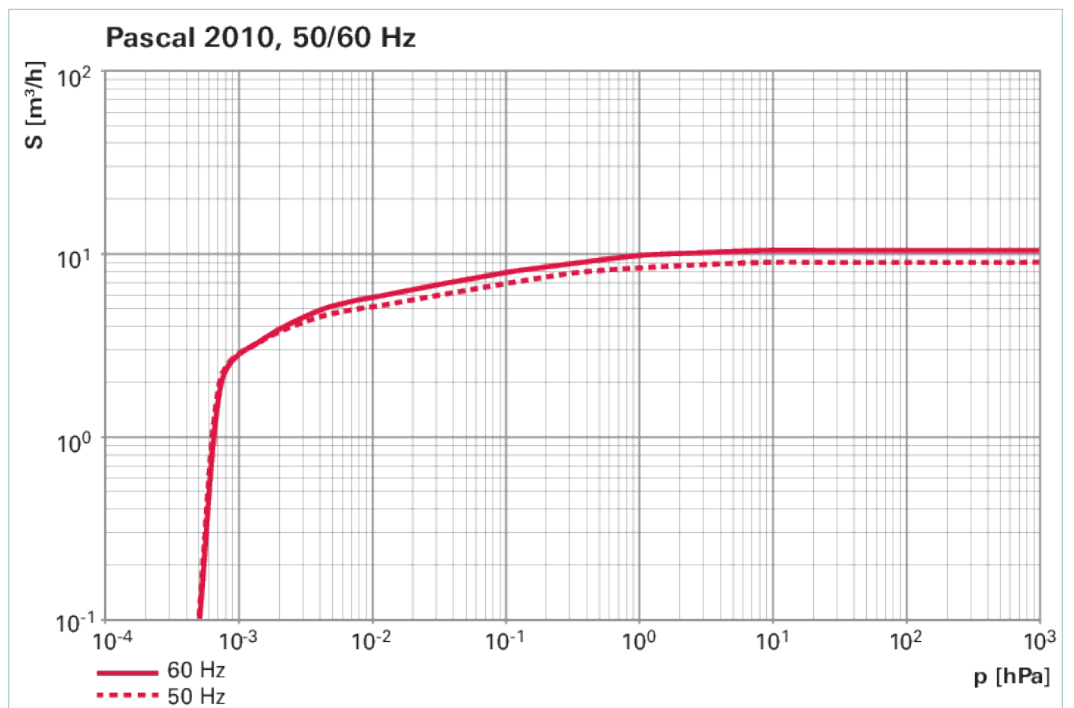

Pascal 2010 , SD 版本 , 三相电机
 , 342 – 460 V , 50 Hz | 342 – 520 V , 60
 Hz , CE/UL/CSA

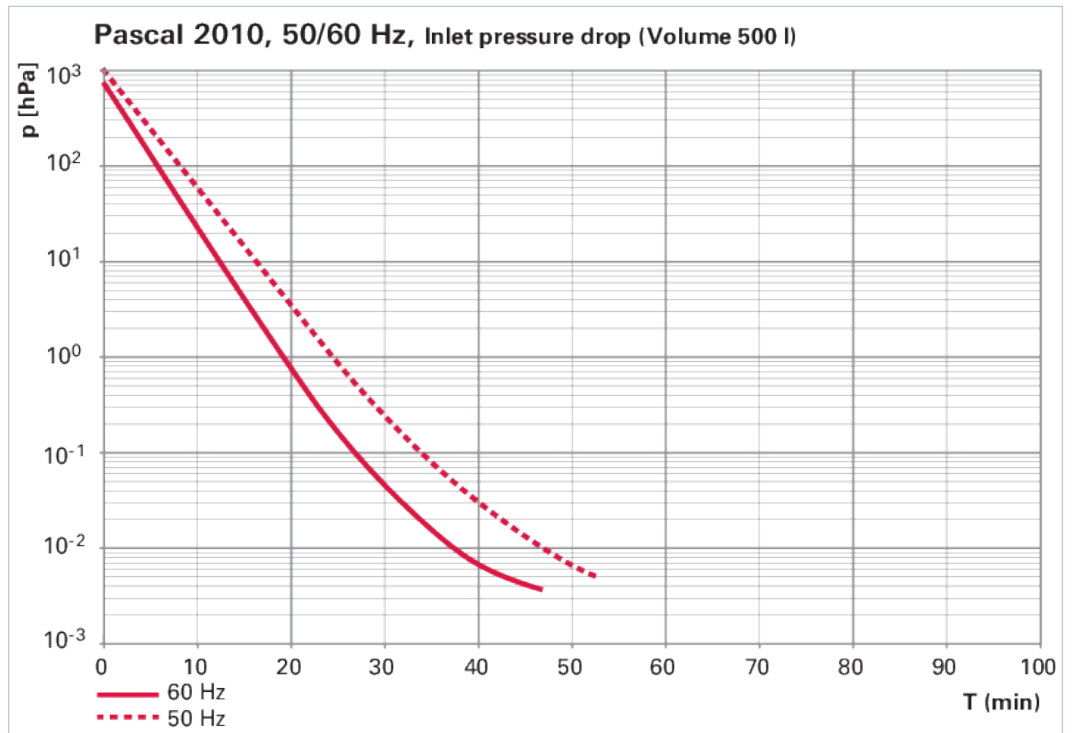

Pascal 2100 , SD 版本 , 三相电机 , 342 – 460 V , 50 Hz | 342 – 520 V , 60 Hz , CE/UL/CSA



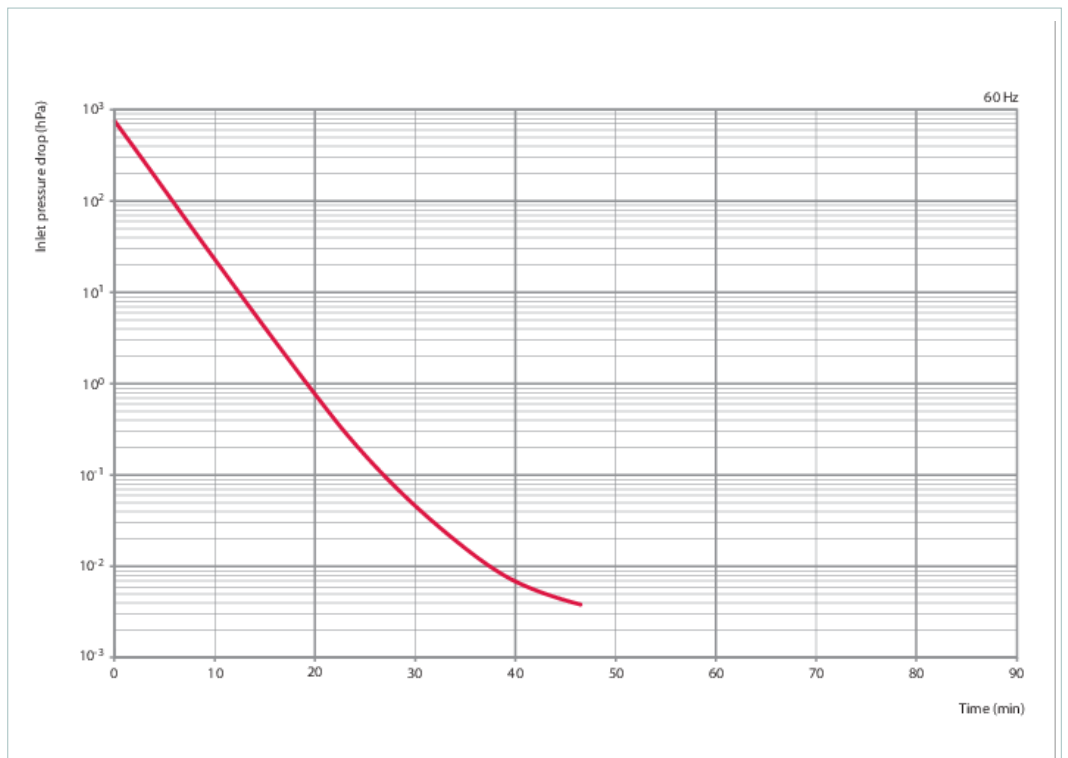

尺寸

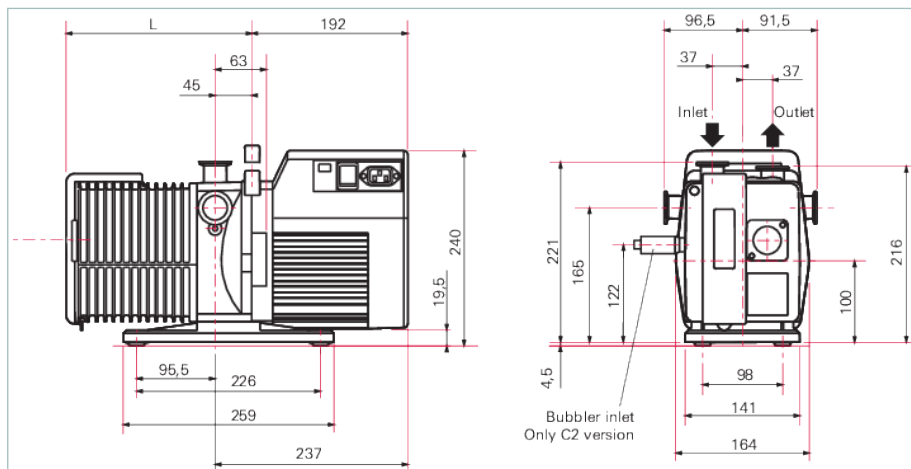

L 245

技术参数	Pascal 2010, SD 版本, 三相电机, 342 – 460 V, 50 Hz 342 – 520 V, 60 Hz, CE/UL/CSA
连接法兰 (入口)	DN 25 ISO-KF
连接法兰 (出口)	DN 25 ISO-KF
50 Hz 时的抽速	9 m/h 5.3 cfm 150 l/min
60 Hz 时的抽速	10.5 m/h 6.18 cfm 175 l/min
最终压力	5 10^{-4}
带气镇的最终压力	1 10^{-2}
不带气镇的最终压力	5 10^{-4}
电机型号	三相电机
电源连接:电压 50 Hz	342 – 460 V
电源连接:电压 60 Hz	342 – 520 V
电源电缆	是, EU 电源线
工作液体	矿物油
额定功率 50 Hz	0.55 千瓦

技术参数	
额定功率 60 Hz	0.66 千瓦
防护等级	IP43
重量	26 千克

订单号	
Pascal 2010 SD	210SDTHEM

配件	
ISO-KF, 焊接波纹管	
高真空角阀, DN 25 ISO-KF, 手动, 不锈钢/氟橡胶, “A” 尺寸 50 mm	ESV-S03100
保护 催化剂阱	
URB 025, 催化阱, 230 V	PT U10 760
URB 025, 催化阱, 115 V	PT U10 761
保护 灰尘分离器/入口粒子过滤器	
SAS 25, 灰尘分离器, DN 25 ISO-KF	PK Z60 508
保护 冷凝分离器	
KAS 25, 用于抽气速率高达 35 m ³ /h	PK Z10 033
保护 冷阱	
冷阱, LN ₂ , 成角式, DN 25 ISO-KF, 4” 基体, 不锈钢/氟化碳橡胶	FTNA-4-1002-NWB
保护 吸附阱	
ST 25 S 吸附阱	104107
保护 油雾分离器的回油装置	
油雾消除器的排油工具 ODK 1	104360
从 OME 25 到 Pascal 2005 – 2021, 电磁阀 230 V 50/60 Hz, 的 OKD 2 回油装置	104361
回油装置 ODK 2, 来自 OME 25, Pascal 2005 – 2021, 电磁阀 115 V, 60 Hz	104362
回油装置 ODK 2, 来自 OME 25, Pascal 2005 – 2021, 电磁阀 200 V, 50/60 Hz	104364
回油装置 ODK 2, 来自 OME 25, Pascal 2005 – 2021, 电磁阀 24 V DC	104365
保护 油雾消除器	
OME 25 S 油雾分离器	104200
OME 25 M, 油雾过滤器, 用于抽速高达 12 m ³ /h	PK Z40 157
阀 气镇阀, 磁力	
自动气镇 AGB 4, 230 V, 50/60 Hz	104086
自动气镇 AGB 4, 115 V	104087
自动气镇 AGB 4, 24 VDC	104089
自动气镇 AGB 4, 200 V, 50/60 Hz	104366
监控 油/工作液液位监控	
油液位开关 OLS 4	104376
耗材	
A120, 烃油, 2 L	068099
A111, 烃油, 2 L	064655
A102, 烃油, 2 L	010996
A119, 烃油, 1 L	103855
A121, 烃油, 1 L	102724
D1, 基于合成二脂的油, 1 l	PK 005 875 -T

VACUUM SOLUTIONS FROM A SINGLE SOURCE

Pfeiffer Vacuum stands for innovative and custom vacuum solutions worldwide, technological perfection, competent advice and reliable service.

COMPLETE RANGE OF PRODUCTS

From a single component to complex systems:

We are the only supplier of vacuum technology that provides a complete product portfolio.

COMPETENCE IN THEORY AND PRACTICE

Benefit from our know-how and our portfolio of training opportunities!

We support you with your plant layout and provide first-class on-site service worldwide.

Are you looking for a
perfect vacuum solution?
Please contact us:

Pfeiffer Vacuum GmbH
Headquarters · Germany
T +49 6441 802-0
info@pfeiffer-vacuum.de

www.pfeiffer-vacuum.com

All data subject to change without prior notice.

PFEIFFER  **VACUUM**