

## Agilent TriScroll 300 Inverter

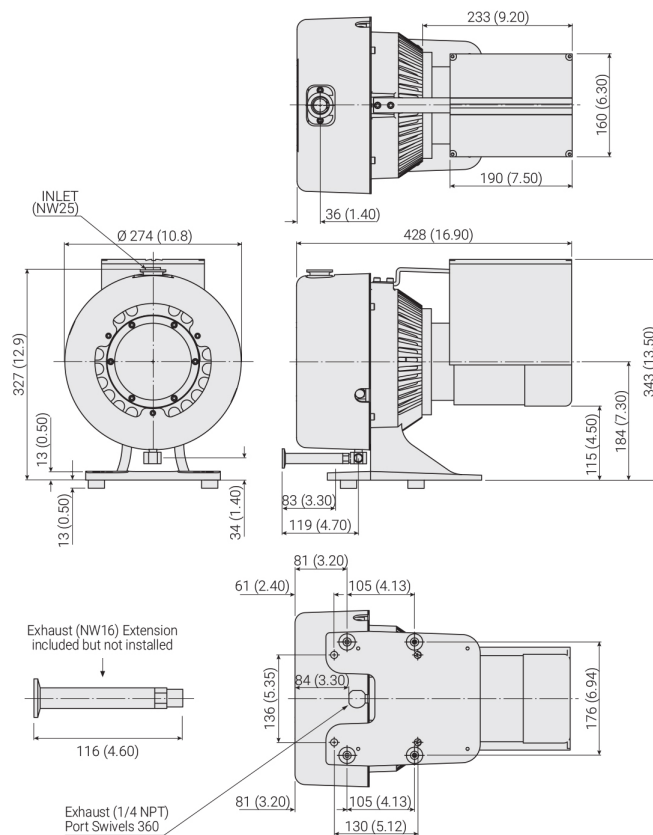

TriScroll Inverter pumps apply the benefits of frequency inverter technology to the performance of Agilent TriScroll dry primary vacuum pumps. TriScroll pumps eliminate the frequent maintenance requirements of oil-sealed rotary vane pumps, simplifying regulatory and environmental compliance, and eliminating oil disposal costs.

- Constant pumping speed worldwide, regardless of line frequency
- Optimal pumping speed selection, adjusting the rotational speed of the pump, using RS-232 or 0 to 10 V control signal
- Monitoring of pump parameters using serial interface
- Remote start/stop with a contact closure made possible by a standard D-shell connector
- Optimal rotational speed selection reduces noise and vibration levels in the work area, with little loss in base pressure performance of the pump

## TriScroll 300 inverter pumping speed: air/N<sub>2</sub>

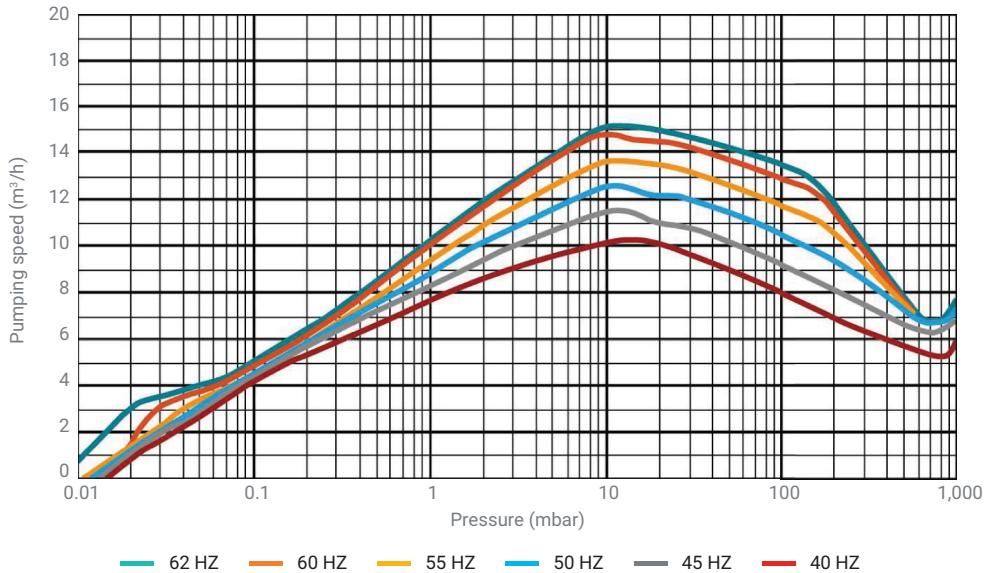

### Technical specifications

Pumping Speed	60 Hz: 250 L/m, 15 m <sup>3</sup> /h, 8.8 cfm (at 60 Hz drive frequency, variable)
Ultimate Pressure	1.3 × 10 <sup>-2</sup> mbar (1.0 × 10 <sup>-2</sup> Torr)
Maximum Inlet Pressure	1.0 atm (0 psig)
Maximum Outlet Pressure	1.1 atm (1.5 psig)
Inlet Connection	NW25
Exhaust Connection	1/4-inch female NPT with swivel (NW16 adapter provided)
Gas Ballast	1/4-inch female NPT (shipped with 40 µm filter installed; port plug also provided)
Operating Voltages	100 to 115 V, 200 to 240 V, 1Ø, 50/60 Hz
Maximum Line Current	200 V; 5 A 240 V; 4.2 A
Weight	Pump only: 26 kg (57 lb) Shipping weight: 34 kg (74 lb)
Certification	CE, CSA, and RoHS

**Note:** Scroll pumps are not suitable for pumping corrosive, explosive, or particulate-forming gases.

### Ordering information

Description	Part Number
TriScroll 300 dry scroll vacuum pump, 1Ø motor, 100 to 240 V	PTS03001 INV
<b>Power Cord Selection</b>	
Europe, 10 A/220 to 230 V, 2.5 m	656494220
Denmark, 10 A/220 to 230 V, 2.5 m	656494225
Switzerland, 10 A/230 V, 2.5 m	656494235
UK/Ireland, 13 A/230 V, 2.5 m	656494250
India, 10 A/220 to 250 V, 2.5 m	656494245
Israel, 10 A/220 to 230 V, 2.5 m	656494230
Japan, 12 A/100 V, 2.3 m	656494240
North America, 15 A/125 V, 2.0 m	656458203
North America, 10 A/230 V, 2.5 m	656494255
<b>Accessories</b>	
Exhaust silencer kit for TriScroll	EXSLRTRISROLL
Vibration isolation kit for TriScroll	PTSVIBISOKIT
NW25 inlet trap with HEPA filter insert	SCRINTRPNW25
Replacement HEPA inlet filter	REPLHEPAFILTER1
Exhaust filter kit, TriScroll 300	PTS300EXFIL
Replacement HEPA exhaust filter	110420110
Purge kit for TriScrolls	PTSPURGEKIT
VPI Valve NW25 120 VAC	VPI251205060
VPI Valve NW25 220 VAC	VPI252205060
<b>Maintenance/Service Parts</b>	
TriScroll 300 exhaust extension	S4707002
TriScroll 300 maintenance kit	PTSS0300MK
TriScroll 300/600 maintenance tool kit	PTSS0600TK
TriScroll 300 replacement tip seal kit	PTSS0300TS
TriScroll 300/600 tip seal tool kit	PTSTSTKIT
TriScroll 300/600 3Ø cable kit	S4789001

[www.agilent.com/en/  
product/vacuum-technologies/  
dry-scroll-pumps](http://www.agilent.com/en/product/vacuum-technologies/dry-scroll-pumps)

DE44236.5774537037

This information is subject to change without notice.

© Agilent Technologies, Inc. 2021  
Printed in the USA, February 11, 2021  
5994-2929EN