

## Agilent TriScroll 600

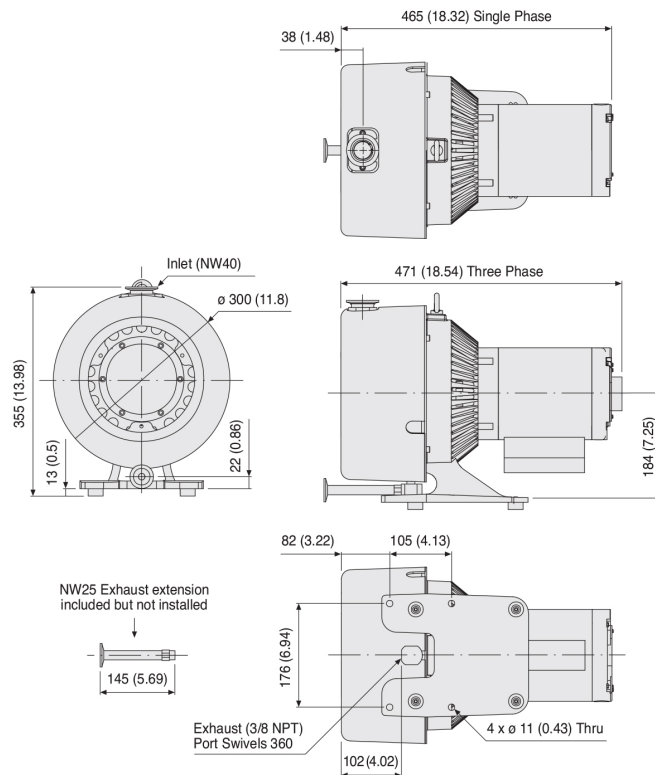

The TriScroll series is a range of two-stage dry scroll pumps that have high pumping speeds and low base pressure. TriScroll pumps eliminate the frequent maintenance requirements of oil-sealed rotary vane pumps, simplifying regulatory and environmental compliance, and eliminating oil disposal costs.

The unique, patented TriScroll pump offers proven reliability and durability, delivering consistent performance and superior cost of ownership.

- Two stage TriScroll design provides high pumping speeds and low ultimate pressure
- Long-life tip seals routinely last more than a year before replacement
- Bearing purge port maximizes bearing life in high water vapor applications
- Automatic air ballast manages water vapor without reducing pumping speed

## TriScroll 600 pumping speed: air/N<sub>2</sub>

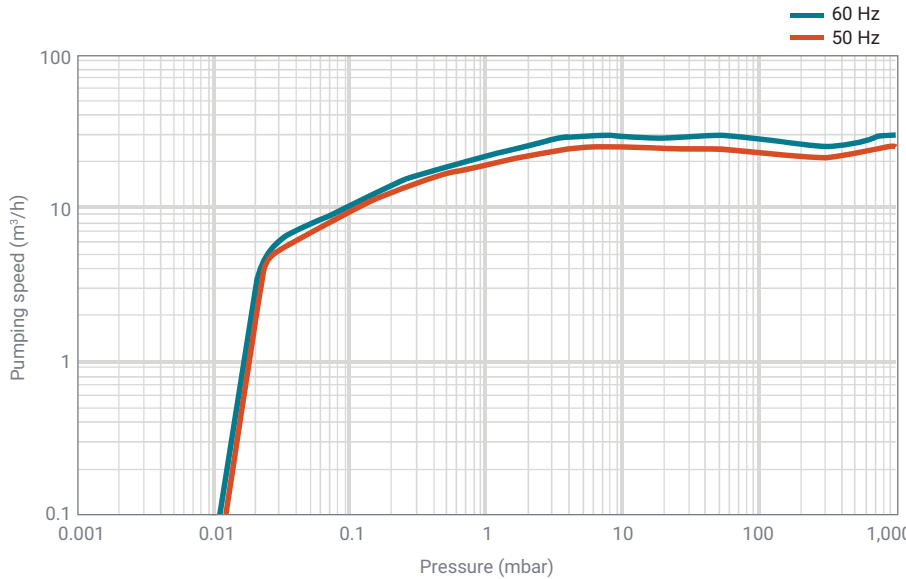

### Technical specifications

Pumping Speed	60 Hz: 500 L/m 30 m <sup>3</sup> /h, 17.7 cfm 50 Hz: 420 L/m, 25.2 m <sup>3</sup> /h, 14.8 cfm
Ultimate Pressure	9.3 × 10 <sup>-3</sup> mbar (7.0 × 10 <sup>-3</sup> Torr)
Maximum Inlet Pressure	1.0 atm (0 psig)
Maximum Outlet Pressure	1.1 atm (1.5 psig)
Inlet Connection	NW40
Exhaust Connection	3/8-inch female NPT with swivel (NW25 adapter provided)
Gas Ballast	1/4-inch female NPT (shipped with 40 µm filter installed; port plug also provided)
Operating Voltages	1Ø models: 50 to 60 Hz/100 to 115, 200 to 230 VAC 3Ø models: 50 Hz/200 to 230, 380 to 415 VAC; 60 Hz/200 to 230, 460 VAC
Weight	Pump only: 32 kg (70 lb) Shipping weight 40 kg (87 lb)
Certification	CE, CSA, and RoHS

**Note:** Scroll pumps are not suitable for pumping corrosive, explosive, or particulate-forming gases.

### Ordering information

Description	Part Number
TriScroll 600 dry scroll vacuum pump, 1Ø motor	PTS06001UNIV
TriScroll 600 dry scroll vacuum pump, 1Ø motor, Euro cord	PTS06001UNIVEU
TriScroll 600 dry scroll vacuum pump, 1Ø motor, UK cord	PTS06001UNIVUK
TriScroll 600 dry scroll vacuum pump, 3Ø phase motor	PTS06003UNIV
TriScroll 600, 1Ø, with vacuum isolation valve (VPI), 120 V	PTS06001UVPI
TriScroll 600, 1Ø, with VPI, 220 V, EU power cord	PTS06001UVPIEU
TriScroll 600, 1Ø, with VPI, 220 V, UK power cord	PTS06001UVPIUK
TriScroll 600, 3Ø, with VPI, 200 V	PTS06003200VPI
TriScroll 600, 3Ø, with VPI, 230 V	PTS06003230VPI
TriScroll 600, 3Ø, with VPI, 380/415 V	PTS06003380415VPI
TriScroll 600, 3Ø, with VPI, 460 V	PTS06003460VPI
TriScroll 600 exhaust extension	S4807001
<b>Accessories</b>	
Exhaust silencer kit for TriScroll	EXSLRTRISROLL
Vibration isolation kit for TriScroll	PTSVIBISOKIT
NW40 inlet trap with HEPA filter insert	SCRINTRPNW40
Replacement HEPA inlet filter	REPLHEPAFILTER1
Exhaust filter kit, TriScroll 600	PTS600EXFIL
Replacement HEPA exhaust filter	110420110
Purge kit for TriScrolls	PTSPURGEKIT
VPI Valve NW40 120 VAC	VPI401205060
VPI Valve NW40 220 VAC	VPI402205060
<b>Maintenance/Service Parts</b>	
TriScroll 300 exhaust extension	S4707002
TriScroll 600 maintenance kit	PTSS0600MK
TriScroll 300/600 maintenance tool kit	PTSS0600TK
TriScroll 600 replacement tip seal kit	PTSS0600TS
TriScroll 300/600 tip seal tool kit	PTSTSTKIT
TriScroll 300/600 3Ø cable kit	S4789001

[www.agilent.com/en/product/vacuum-technologies/dry-scroll-pumps](http://www.agilent.com/en/product/vacuum-technologies/dry-scroll-pumps)

DE44236.5739236111

This information is subject to change without notice.

© Agilent Technologies, Inc. 2021  
Printed in the USA, February 10, 2021  
5994-2926EN