

OPERATING INSTRUCTIONS

EN

Translation of the Original

MVP 015-2 DC

Diaphragm pump

PFEIFFER  **VACUUM**

Dear Customer,

Thank you for choosing a Pfeiffer Vacuum product. Your new diaphragm pump is designed to support you with its performance, perfect operation and without impacting your individual application. The name Pfeiffer Vacuum stands for high-quality vacuum technology, a comprehensive and complete range of top-quality products and first-class service. From this extensive, practical experience we have gained a large volume of information that can contribute to efficient deployment and to your personal safety.

In the knowledge that our product must avoid consuming work output, we trust that our product can offer you a solution that supports you in the effective and trouble-free implementation of your individual application.

Please read these operating instructions before putting your product into operation for the first time. If you have any questions or suggestions, please feel free to contact info@pfeiffer-vacuum.de.

Further operating instructions from Pfeiffer Vacuum can be found in the [Download Center](#) on our website.

Disclaimer of liability

These operating instructions describe all models and variants of your product. Note that your product may not be equipped with all features described in this document. Pfeiffer Vacuum constantly adapts its products to the latest state of the art without prior notice. Please take into account that online operating instructions can deviate from the printed operating instructions supplied with your product.

Furthermore, Pfeiffer Vacuum assumes no responsibility or liability for damage resulting from the use of the product that contradicts its proper use or is explicitly defined as foreseeable misuse.

Copyright

This document is the intellectual property of Pfeiffer Vacuum and all contents of this document are protected by copyright. They may not be copied, altered, reproduced or published without the prior written permission of Pfeiffer Vacuum.

We reserve the right to make changes to the technical data and information in this document.

Table of contents

1	About this manual	7
1.1	Validity	7
	1.1.1 Applicable documents	7
	1.1.2 Variants	7
1.2	Target group	7
1.3	Conventions	7
	1.3.1 Instructions in the text	7
	1.3.2 Pictographs	7
	1.3.3 Stickers on the product	8
	1.3.4 Abbreviations	8
2	Safety	10
2.1	General safety information	10
2.2	Safety instructions	10
2.3	Safety precautions	13
2.4	Limits of use of the product	13
2.5	Proper use	14
2.6	Foreseeable improper use	14
2.7	Personnel qualification	14
	2.7.1 Ensuring personnel qualification	15
	2.7.2 Personnel qualification for maintenance and repair	15
	2.7.3 Advanced training with Pfeiffer Vacuum	15
3	Product description	16
3.1	Function	16
	3.1.1 Drive	16
	3.1.2 Pumping system	16
	3.1.3 Cooling	16
	3.1.4 Gas ballast	16
3.2	Connections	17
3.3	Identifying the product	17
3.4	Scope of delivery	17
4	Transportation and Storage	18
4.1	Transporting the vacuum pump	18
4.2	Storing the vacuum pump	18
5	Installation	19
5.1	Installing the vacuum pump	19
5.2	Connecting the vacuum side	19
5.3	Connecting the exhaust side	19
5.4	Establishing the electric connection	20
	5.4.1 Ground the vacuum pump	20
	5.4.2 Establishing the electric connection	21
6	Interfaces	23
6.1	"Remote" interface	23
	6.1.1 Voltage supply	23
	6.1.2 Inputs	24
	6.1.3 Outputs	24
	6.1.4 RS-485	24
6.2	Interface RS-485	25
6.3	Cross-linked via the RS-485 connection	26
6.4	Pfeiffer Vacuum protocol for RS-485 interface	26
	6.4.1 Telegram frame	26
	6.4.2 Telegram description	27
	6.4.3 Telegram example 1	27

	6.4.4 Telegram example 2	27
	6.4.5 Data types	28
7	Parameter set	29
	7.1 General	29
	7.2 Control commands	29
	7.3 Status requests	30
	7.4 Reference value inputs	31
	7.5 Additional parameter for the DCU	31
8	Operation	32
	8.1 Putting the vacuum pump into operation	32
	8.2 Switching on the vacuum pump	32
	8.3 Operating the diaphragm pump with gas ballast	33
	8.4 Configuring the connections with the Pfeiffer Vacuum parameter set	33
	8.4.1 Configuring the digital outputs	33
	8.4.2 Selecting the interfaces	34
	8.5 Operating modes	34
	8.5.1 Normal operation	35
	8.5.2 Stand-by operation	35
	8.5.3 Speed actuator operation	35
	8.5.4 Gas ballast valve control	36
	8.6 Operation monitoring	36
	8.6.1 Operating mode display via LED	36
	8.6.2 Temperature monitoring	36
	8.7 Switching off the vacuum pump	37
9	Maintenance	38
	9.1 Maintenance instructions	38
	9.2 Checklist for inspection and maintenance	39
	9.3 Change the diaphragms and valves	40
	9.3.1 Dismantle the diaphragm head and valves	40
	9.3.2 Cleaning and replacing the diaphragms and valves	41
	9.3.3 Mount the diaphragm head and valves	41
10	Decommissioning	42
11	Recycling and disposal	43
	11.1 General disposal information	43
	11.2 Dispose of diaphragm pumps	43
12	Malfunctions	44
	12.1 General	44
	12.2 Error codes	45
	12.3 Warning and error messages when operating with DCU	46
13	Service solutions by Pfeiffer Vacuum	47
14	Spare parts packages	49
15	Accessories	50
	15.1 Accessory information	50
	15.2 Ordering accessories	50
16	Technical data and dimensions	51
	16.1 General	51
	16.2 Technical data	51
	16.3 Substances in contact with the media	52
	16.4 Dimensions	53
	Declaration of conformity	54

List of tables

Tbl. 1:	Stickers on the product	8
Tbl. 2:	Abbreviations used in this document	9
Tbl. 3:	Permissible ambient conditions	14
Tbl. 4:	Connection description of the electronic drive unit	17
Tbl. 5:	Plug arrangement of the D-Sub socket, 15-pin	23
Tbl. 6:	Features of the RS-485 interface	25
Tbl. 7:	Explanation and meaning of the parameters	29
Tbl. 8:	Parameter set Control commands	30
Tbl. 9:	Parameter set Status requests	30
Tbl. 10:	Parameter set Reference value inputs	31
Tbl. 11:	Parameter for DCU functions	31
Tbl. 12:	Factory setting of the electronic drive unit for diaphragm pumps when delivered	32
Tbl. 13:	Configure parameters [P:019] and [P:024]	34
Tbl. 14:	Parameters [P:060] and [P:061]	34
Tbl. 15:	Behavior and meaning of the LED of the electronic drive unit	36
Tbl. 16:	Typical service life with normal use	38
Tbl. 17:	Maintenance intervals	39
Tbl. 18:	Troubleshooting on diaphragm pumps	45
Tbl. 19:	Error messages for vacuum pump	45
Tbl. 20:	Warning messages for vacuum pump	45
Tbl. 21:	Warning and error messages when using a DCU	46
Tbl. 22:	Spare parts	49
Tbl. 23:	Accessories MVP 015-2 DC	50
Tbl. 24:	Conversion table: Pressure units	51
Tbl. 25:	Conversion table: Units for gas throughput	51
Tbl. 26:	Technical data MVP 015-2 DC	52
Tbl. 27:	Materials that make contact with the process media	52

List of figures

Fig. 1:	Position of the stickers on the product	8
Fig. 2:	Diaphragm pump design	16
Fig. 3:	Connect grounding cable	20
Fig. 4:	Connection of the electronic drive unit to the power supply and DCU	21
Fig. 5:	Connecting the electronic drive unit to the power supply, DCU and turbo-pump	22
Fig. 6:	Pin assignment of the D-Sub socket, 15-pin	23
Fig. 7:	Connection options via interface RS-485	25
Fig. 8:	Networking via the RS-485 interface	26
Fig. 9:	Gas ballast valve control diagram	36
Fig. 10:	Diaphragm head and valves	40
Fig. 11:	Spare parts	49
Fig. 12:	Dimensions MVP 015-2 DC	53

1 About this manual



IMPORTANT

Read carefully before use.
Keep the manual for future consultation.

1.1 Validity

This operating instructions is a customer document of Pfeiffer Vacuum. The operating instructions describe the functions of the named product and provide the most important information for the safe use of the device. The description is written in accordance with the valid directives. The information in this operating instructions refers to the product's current development status. The document shall remain valid provided that the customer does not make any changes to the product.

1.1.1 Applicable documents

Designation	Document
Declaration of conformity	A component of these operating instructions

1.1.2 Variants

These instructions apply to diaphragm pumps of the DC series:

- MVP 015-2 DC

1.2 Target group

These operating instructions are aimed at all persons performing the following activities on the product:

- Transportation
- Setup (Installation)
- Usage and operation
- Decommissioning
- Maintenance and cleaning
- Storage or disposal

The work described in this document is only permitted to be performed by persons with the appropriate technical qualifications (expert personnel) or who have received the relevant training from Pfeiffer Vacuum.

1.3 Conventions

1.3.1 Instructions in the text

Usage instructions in the document follow a general structure that is complete in itself. The required action is indicated by an individual step or multi-part action steps.

Individual action step

A horizontal, solid triangle indicates the only step in an action.

- ▶ This is an individual action step.

Sequence of multi-part action steps

The numerical list indicates an action with multiple necessary steps.

1. Step 1
2. Step 2
3. ...

1.3.2 Pictographs

Pictographs used in the document indicate useful information.



Note



Tip

1.3.3 Stickers on the product

This section describes all the stickers on the product along with their meanings.

	<p>Rating plate (example) The rating plate is located on the cover of the electronics.</p>
	<p>Warranty seal The diaphragm heads are sealed at the factory. Damaging or removing a warranty seal results in loss of the warranty.</p>
	<p>Warning of hot surfaces This sticker warns of injuries caused by high temperatures as a result of contact without protection during operation.</p>

Tbl. 1: Stickers on the product

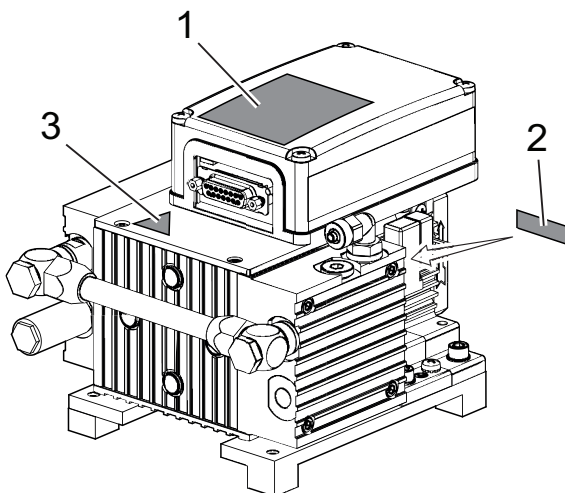

Fig. 1: Position of the stickers on the product

- 1 Rating plate of the diaphragm pump
- 2 Warranty seal
- 3 Hot surface warning sign

1.3.4 Abbreviations

Abbreviation	Meaning in this document
DC	Direct current
DCU	Display and Control Unit from Pfeiffer Vacuum.
DN	Nominal diameter (diamètre nominal)
f	Rotation speed value of a vacuum pump (frequency, in rpm or Hz)
HPU	Handheld Programming Unit, aid for controlling and monitoring pump parameters
LED	Light emitting diode

Abbreviation	Meaning in this document
MVP	Diaphragm vacuum pump
MSL	Mean sea level
[P:xxx]	Electronic drive unit control parameters. Printed in bold as a three-digit number in square brackets. Frequently displayed in conjunction with a short description. Example: [P:312] software version
PE	Earthed conductor (protective earth)
PWM	Pulse width modulation (Type of modulation where one technical variable (e.g. electrical voltage) changes between two values.)
T	Temperature (in °C), property abbreviation of the vacuum pump
TC	Turbopump electronic drive unit (turbo controller)
TPS	Voltage supply (turbo power supply)

Tbl. 2: Abbreviations used in this document

2 Safety

2.1 General safety information

The following 4 risk levels and 1 information level are taken into account in this document.

⚠ DANGER
<p>Immediately pending danger Indicates an immediately pending danger that will result in death or serious injury if not observed.</p> <ul style="list-style-type: none"> ▶ Instructions to avoid the danger situation

⚠ WARNING
<p>Potential pending danger Indicates a pending danger that could result in death or serious injury if not observed.</p> <ul style="list-style-type: none"> ▶ Instructions to avoid the danger situation

⚠ CAUTION
<p>Potential pending danger Indicates a pending danger that could result in minor injuries if not observed.</p> <ul style="list-style-type: none"> ▶ Instructions to avoid the danger situation

NOTICE
<p>Danger of damage to property Is used to highlight actions that are not associated with personal injury.</p> <ul style="list-style-type: none"> ▶ Instructions to avoid damage to property

i	Notes, tips or examples indicate important information about the product or about this document.
----------	--

2.2 Safety instructions

All safety instructions in this document are based on the results of the risk assessment carried out in accordance with Machinery Directive 2006/42/EC Annex I and EN ISO 12100 Section 5. Where applicable, all life cycle phases of the product were taken into account.

Risks during transport

⚠ WARNING
<p>Danger of serious injury due to falling objects Due to falling objects there is a risk of injuries to limbs through to broken bones.</p> <ul style="list-style-type: none"> ▶ Take particular care and pay special attention when transporting products manually. ▶ Do not stack the products. ▶ Wear protective equipment, e.g. safety shoes.

Risks during installation

⚠ DANGER**Danger to life from electric shock**

Power supply packs that are not specified or are not approved will lead to severe injury to death.

- ▶ Make sure that the power supply pack meets the requirements for double isolation between mains input voltage and output voltage, in accordance with IEC 61010-1 IEC 60950-1 and IEC 62368-1.
- ▶ Make sure that the power supply pack meets the requirements in accordance with IEC 61010-1 IEC 60950-1 and IEC 62368-1.
- ▶ Where possible, use original power supply packs or only power supply packs that correspond with the applicable safety regulations.

⚠ DANGER**Danger to life from electric shock**

When establishing the voltages that exceed the specified safety extra-low voltage (according to IEC 60449 and VDE 0100), the insulating measures will be destroyed. There is a danger to life from electric shock at the communication interfaces.

- ▶ Connect only suitable devices to the bus system.

⚠ WARNING**Risk of injury due to incorrect installation**

Dangerous situations may arise from unsafe or incorrect installation.

- ▶ Do not carry out your own conversions or modifications on the unit.
- ▶ Ensure the integration into an Emergency Off safety circuit.

⚠ CAUTION**Danger of injury from bursting as a result of high pressure in the exhaust line**

Faulty or inadequate exhaust pipes lead to dangerous situations, e.g. increased exhaust pressure. There is a danger of bursting. Injuries caused by flying fragments, the escaping of high pressure, and damage to the unit cannot be excluded.

- ▶ Route the exhaust line without shut-off units.
- ▶ Observe the permissible pressures and pressure differentials for the product.
- ▶ Check the function of the exhaust line on a regular basis.

Risks during operation

⚠ WARNING**Danger of poisoning due to toxic process media escaping from the exhaust pipe**

During operation with no exhaust line, the vacuum pump allows exhaust gases and vapors to escape freely into the air. There is a risk of injury and fatality due to poisoning in processes with toxic process media.

- ▶ Observe the pertinent regulations for handling toxic process media.
- ▶ Safely purge toxic process media via an exhaust line.
- ▶ Use appropriate filter equipment to separate toxic process media.

⚠ WARNING**Explosion hazard from reactive, potentially explosive or other hazardous gas/air mixtures**

Uncontrolled inlet of gas at the gas ballast valve leads to sparks generated mechanically following diaphragm rupture, hot surfaces or to potentially explosive gas/air mixtures in the vacuum system caused by static electricity.

- ▶ If necessary, use inert gas for supplying the flushing gas in order to avoid a potential ignition.

⚠ WARNING

Risk of poisoning due to toxic process gases escaping

For intake pressures > 500 hPa, process gas may escape from the open gas ballast valve. There is a risk of injury and fatality due to poisoning in processes with toxic process media.

- ▶ If necessary, use inert gas to avoid potential contamination.
- ▶ If necessary, use an extraction line.

⚠ CAUTION

Danger of burns on hot surfaces

Depending on the operating and ambient conditions, the surface temperature of the vacuum pump can increase to above 70 °C.

- ▶ Provide suitable touch protection.

Risks during maintenance, decommissioning and in the event of malfunctions

⚠ WARNING

Health hazard through poisoning from toxic contaminated components or devices

Toxic process media result in contamination of devices or parts of them. During maintenance work, there is a risk to health from contact with these poisonous substances. Illegal disposal of toxic substances causes environmental damage.

- ▶ Take suitable safety precautions and prevent health hazards or environmental pollution by toxic process media.
- ▶ Decontaminate affected parts before carrying out maintenance work.
- ▶ Wear protective equipment.

⚠ CAUTION

Danger of injury from moving parts

After a power failure or a standstill as a result of overheating, the motor restarts automatically. There is a risk of injury to fingers and hands if they enter the operating range of rotating parts.

- ▶ Safely disconnect motor from the mains.
- ▶ Secure the motor against reactivation.
- ▶ Dismantle the vacuum pump for inspection, away from the system if necessary.

⚠ CAUTION

Danger of burns on hot surfaces

In the event of a fault, the surface temperature of the vacuum pump can increase to above 105 °C.

- ▶ Allow the vacuum pump to cool down before carrying out any work.
- ▶ Wear personal protective equipment if necessary.

Risks during disposal

⚠ WARNING

Health hazard through poisoning from toxic contaminated components or devices

Toxic process media result in contamination of devices or parts of them. During maintenance work, there is a risk to health from contact with these poisonous substances. Illegal disposal of toxic substances causes environmental damage.

- ▶ Take suitable safety precautions and prevent health hazards or environmental pollution by toxic process media.
- ▶ Decontaminate affected parts before carrying out maintenance work.
- ▶ Wear protective equipment.

2.3 Safety precautions

DANGER

Danger to life from electric shock

Power supply packs that are not specified or are not approved will lead to severe injury to death.

- ▶ Make sure that the power supply pack meets the requirements for double isolation between mains input voltage and output voltage, in accordance with IEC 61010-1 IEC 60950-1 and IEC 62368-1.
- ▶ Make sure that the power supply pack meets the requirements in accordance with IEC 61010-1 IEC 60950-1 and IEC 62368-1.
- ▶ Where possible, use original power supply packs or only power supply packs that correspond with the applicable safety regulations.



Duty to provide information on potential dangers

The product holder or user is obliged to make all operating personnel aware of dangers posed by this product.

Every person who is involved in the installation, operation or maintenance of the product must read, understand and adhere to the safety-related parts of this document.



Infringement of conformity due to modifications to the product

The Declaration of Conformity from the manufacturer is no longer valid if the operator changes the original product or installs additional equipment.

- Following the installation into a system, the operator is required to check and re-evaluate the conformity of the overall system in the context of the relevant European Directives, before commissioning that system.

General safety precautions

- ▶ Prevent process gases and their reaction and ancillary products that are harmful to health and the environmental from escaping, or dispose of these according to the applicable regulations.
- ▶ Avoid contact with process gases that are harmful to health and if required, wear personal protective clothing.
- ▶ Check the media compatibility of parts carrying media.
- ▶ Observe all applicable safety and accident prevention regulations.
- ▶ Check that all safety measures are observed at regular intervals.
- ▶ Do not expose body parts to the vacuum.
- ▶ Never disconnect plug connections during operation.
- ▶ Never fill or operate the unit with cleaning agents or cleaning agent residues.
- ▶ Do not carry out your own conversions or modifications on the unit.
- ▶ Observe the unit protection degree prior to installation or operation in other environments.
- ▶ Provide suitable touch protection, if the surface temperature exceeds 70°C.
- ▶ Keep lines and cables away from hot surfaces.
- ▶ Before returning the vacuum pump, observe the notes in the chapter Service solutions.

2.4 Limits of use of the product

Installation location	Interiors, protected against the accumulation of dust and weather influences, in a non-explosive, dry environment
Protection degree IEC 60529	IP 20
Protection degree UL 50E	NEMA type 1
Installation altitude	max. 2000 m above sea level ¹⁾
Ambient temperature	+5 °C to +40 °C

1) at an installation location above 1000 meters above sea level, there is a risk of insufficient cooling. If necessary, take measures according to Directive DIN EN 61010.

Permissible intake temperature of medium to be pumped	+5 °C to +40 °C
Relative air humidity	80% at T ≤ 31 °C, to max. 50% at T ≤ 40 °C
Degree of contamination	2

Tbl. 3: Permissible ambient conditions

2.5 Proper use

- ▶ Use the vacuum pump for vacuum generation only.
- ▶ Adhere to the installation, commissioning, operating, and maintenance instructions.
- ▶ Do not use any accessory parts other than those recommended by Pfeiffer Vacuum.

2.6 Foreseeable improper use

Improper use of the product invalidates all warranty and liability claims. Any use that is counter to the purpose of the product, whether intentional or unintentional, is regarded as improper use; in particular:

- Pumping of corrosive media
- Pumping of explosive media
- Pumping radioactive or volatile media
- Pumping of gases that contain impurities such as particles, dust, or condensate
- Pumping of fluids
- Pumping FPM-solubilizing media
- Pumping vapors from combustible liquids
- Pumping pressurized media (> atmospheric pressure)
- Pumping media that can condense or cause adhering deposits to form in the suction chamber
- Use of the vacuum pump outside the specified area of application
- Using the vacuum pump below ground
- Using the vacuum pump to generate pressure
- Using the vacuum pump in systems in which sporadic loads and vibrations or periodic forces act on the unit
- Using the vacuum pump in strong electrical, magnetic, or electromagnetic fields
- Connection to vacuum pumps or equipment which are not suitable for this purpose according to their operating instructions
- Connection to devices with exposed live parts
- Connecting to sockets without earthing contact
- Using pipes to lift the vacuum pump
- Use of accessories or spare parts that are not listed in these instructions
- Using the vacuum pump as a climbing aid
- Using the connection lines between the diaphragm heads as carrying handles
- Using the pump in ambient conditions that do not meet the specified IP protection degree limits

2.7 Personnel qualification

The work described in this document may only be carried out by persons who have appropriate professional qualifications and the necessary experience or who have completed the necessary training as provided by Pfeiffer Vacuum.

Training people

1. Train the technical personnel on the product.
2. Only let personnel to be trained work with and on the product when under the supervision of trained personnel.
3. Only allow trained technical personnel to work with the product.
4. Before starting work, make sure that the commissioned personnel have read and understood these operating instructions and all applicable documents, in particular the safety, maintenance and repair information.

2.7.1 Ensuring personnel qualification

Specialist for mechanical work

Only a trained specialist may carry out mechanical work. Within the meaning of this document, specialists are people responsible for construction, mechanical installation, troubleshooting and maintenance of the product, and who have the following qualifications:

- Qualification in the mechanical field in accordance with nationally applicable regulations
- Knowledge of this documentation

Specialist for electrotechnical work

Only a trained electrician may carry out electrical engineering work. Within the meaning of this document, electricians are people responsible for electrical installation, commissioning, troubleshooting, and maintenance of the product, and who have the following qualifications:

- Qualification in the electrical engineering field in accordance with nationally applicable regulations
- Knowledge of this documentation

In addition, these individuals must be familiar with applicable safety regulations and laws, as well as the other standards, guidelines, and laws referred to in this documentation. The above individuals must have an explicitly granted operational authorization to commission, program, configure, mark, and earth devices, systems, and circuits in accordance with safety technology standards.

Trained individuals

Only adequately trained individuals may carry out all works in other transport, storage, operation and disposal fields. Such training must ensure that individuals are capable of carrying out the required activities and work steps safely and properly.

2.7.2 Personnel qualification for maintenance and repair



Advanced training courses

Pfeiffer Vacuum offers advanced training courses to maintenance levels 2 and 3.

Adequately trained individuals are:

- **Maintenance level 1**
 - Customer (trained specialist)
- **Maintenance level 2**
 - Customer with technical education
 - Pfeiffer Vacuum service technician
- **Maintenance level 3**
 - Customer with Pfeiffer Vacuum service training
 - Pfeiffer Vacuum service technician

2.7.3 Advanced training with Pfeiffer Vacuum

For optimal and trouble-free use of this product, Pfeiffer Vacuum offers a comprehensive range of courses and technical trainings.

For more information, please contact [Pfeiffer Vacuum technical training](#).

3 Product description

3.1 Function

Diaphragm pumps are dry compressing displacement pumps. The movement of diaphragms generates a periodic change of the suction chamber volume. The gas flow causes the valves to open and close automatically. The pump unit is directly connected to the drive motor.

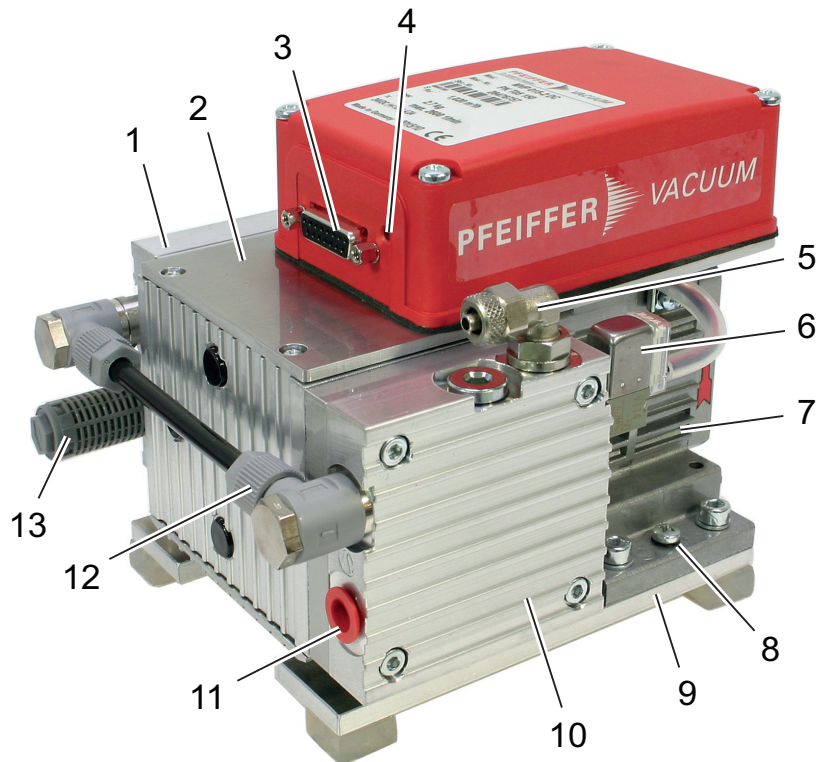

Fig. 2: Diaphragm pump design

- | | |
|--------------------------------------|-----------------------------------|
| 1 Diaphragm head 2 | 8 Grounding screw |
| 2 Cover | 9 Base plate |
| 3 Connecting socket | 10 Diaphragm head 1 |
| 4 LED | 11 Vacuum connection, 1/8" thread |
| 5 Gas ballast connection | 12 Hose connection |
| 6 Gas ballast valve (solenoid valve) | 13 Exhaust with silencer |
| 7 Motor | |

3.1.1 Drive

The diaphragm pump forms a compact unit with the electronic drive unit. The integrated electronic drive unit permits the control and monitoring of pumping functions via the "remote" interface using a Pfeiffer Vacuum display and control unit.

3.1.2 Pumping system

The diaphragm pump has 2 diaphragm heads and 2 pumping stages.

3.1.3 Cooling

The diaphragm pump is convection-cooled and does not have its own fan.

3.1.4 Gas ballast

An integrated gas ballast system serves the controlled supply of ambient air or inert gas into the suction chamber. Gas ballast supports the reduction of condensate accumulating in the pumping system.

3.2 Connections

Connection	Description
	remote D-sub socket with 15 pins for connection and configuration of a remote control.

Tbl. 4: Connection description of the electronic drive unit

3.3 Identifying the product

- ▶ To ensure clear identification of the product when communicating with Pfeiffer Vacuum, always keep all of the information on the rating plate to hand.
- ▶ Learn about certifications through test seals on the product or at www.tuev-sued.de.

3.4 Scope of delivery

- Vacuum pump with drive
- Silencer
- Operating instructions
- Blind plug on the vacuum connection

4 Transportation and Storage

4.1 Transporting the vacuum pump

WARNING

Danger of serious injury due to falling objects

Due to falling objects there is a risk of injuries to limbs through to broken bones.

- ▶ Take particular care and pay special attention when transporting products manually.
- ▶ Do not stack the products.
- ▶ Wear protective equipment, e.g. safety shoes.



Packing

We recommend keeping the transport packaging and original protective cover.

General information regarding safe transport

1. Observe the weight specified on the packaging.
2. Where possible, always transport or ship the product in the original packaging.
3. Always place the product on an adequately sized, level surface.

Transporting the vacuum pump without its packaging

1. Unpack the vacuum pump.
2. To protect the inside of the pump, leave the blind plugs on the vacuum connection during transport.
3. Lift the vacuum pump on both front sides.
4. Lift the vacuum pump out of the transport packaging.
5. Make sure that no forces are acting on the piping system.
6. Always place the vacuum pump on an adequately sized, level surface.

4.2 Storing the vacuum pump



Packing

We recommend storing the product in its original packaging.

Procedure

1. Seal the vacuum connection with the blind plug.
2. Store the vacuum pump only in dry, dust-free rooms, within the specified ambient conditions.
3. In rooms with humid or aggressive atmospheres: Hermetically seal the vacuum pump together with a drying agent in a plastic bag.

5 Installation

5.1 Installing the vacuum pump

Procedure

- ▶ Place the vacuum pump on a flat, horizontal surface.
- ▶ For stationary installation, screw the vacuum pump direct to the mounting surface.
 - Dismantle the base plate for this.
- ▶ When installing the pump in a closed housing, ensure adequate air circulation.
- ▶ Keep the specifications on the motor rating plate visible and freely accessible.

5.2 Connecting the vacuum side

NOTICE

Property damage from contaminated gases

Pumping gases that contain contamination damages the vacuum pump.

- ▶ Use suitable filters or separators from the Pfeiffer Vacuum range of accessories, to protect the vacuum pump.



Installation and operation of accessories

Pfeiffer Vacuum offers a series of special, compatible accessories for its diaphragm pumps.

- Information and ordering options for approved [accessories](#) can be found online.
- Described accessories are not included in the shipment.



Preventing throttling losses

Using the shortest possible vacuum connection lines with large nominal diameter prevents pressure losses.



Condensate separator

Pfeiffer Vacuum recommends the installation of a condensate separator in case vapors are formed from moisture during evacuation.

Procedure

1. Remove the blind plug from the vacuum connection.
2. Establish the shortest possible connection between vacuum pump and vacuum chamber.
3. Choose a minimum vacuum line diameter equal to the nominal diameter of the vacuum connection.
4. Depending on the pump type, use PVC or metallic hoses with flange connections from the [Pfeiffer Vacuum component shop](#).
5. Connect the vacuum pump to the vacuum system using the vacuum connection.

5.3 Connecting the exhaust side

⚠ WARNING

Danger to life from poisoning where toxic process gases leak with no exhaust line

During normal operation, the vacuum pump expels exhaust gases and vapors freely into the air. In processes involving toxic media, there is a risk of injury and danger to life due to poisoning.

- ▶ Observe the relevant regulations for handling toxic substances.
- ▶ Safely purge toxic process gases via an exhaust line.

⚠ CAUTION

Danger of injury from bursting as a result of high pressure in the exhaust line

Faulty or inadequate exhaust pipes lead to dangerous situations, e.g. increased exhaust pressure. There is a danger of bursting. Injuries caused by flying fragments, the escaping of high pressure, and damage to the unit cannot be excluded.

- ▶ Route the exhaust line without shut-off units.
- ▶ Observe the permissible pressures and pressure differentials for the product.
- ▶ Check the function of the exhaust line on a regular basis.

 **Condensate separator**

Pfeiffer Vacuum recommends installing a condensate separator, with condensate drain at the lowest point of the exhaust line.

- Procedure**
1. Check the installed silencer for free passage.
 2. Choose a minimum exhaust line diameter equal to the nominal diameter of the connection flange.
 3. Depending on the pump type, use PVC or metallic hoses with flange connections from the [Pfeiffer Vacuum component shop](#).
 4. Option: In case of higher gas throughputs, mount an exhaust line.
 5. Route the piping downwards from the vacuum pump, to prevent condensate return.
 6. Support or suspend the piping to the vacuum pump so that no piping system forces act on the vacuum pump.

5.4 Establishing the electric connection

⚠ WARNING

Risk of injury due to incorrect installation

Dangerous situations may arise from unsafe or incorrect installation.

- ▶ Do not carry out your own conversions or modifications on the unit.
- ▶ Ensure the integration into an Emergency Off safety circuit.

5.4.1 Ground the vacuum pump

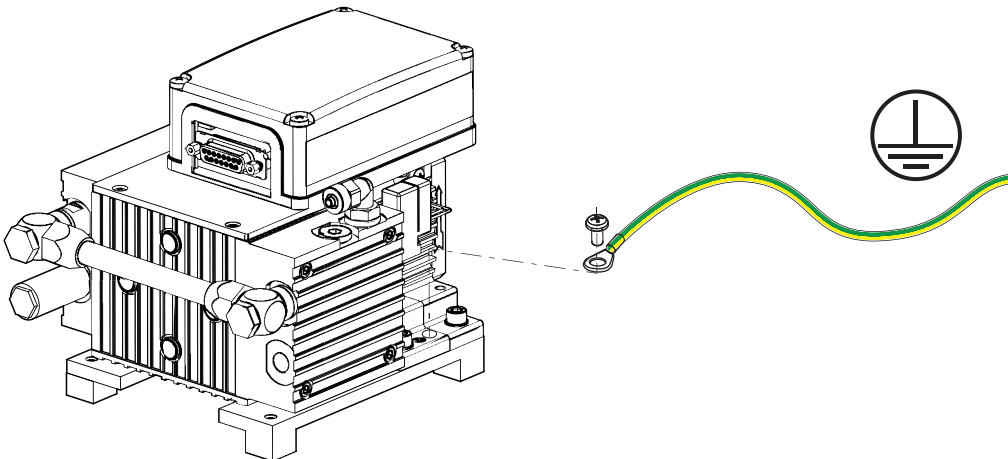

Fig. 3: Connect grounding cable

- Procedure**
1. Use a suitable grounding cable to divert applicative interferences.
 2. Route the connection in accordance with locally applicable provisions.
 3. On the vacuum pump, use the designated ground terminal on the fixing plate (M4 female thread).

5.4.2 Establishing the electric connection

⚠ DANGER

Danger to life from electric shock

Power supply packs that are not specified or are not approved will lead to severe injury to death.

- ▶ Make sure that the power supply pack meets the requirements for double isolation between mains input voltage and output voltage, in accordance with IEC 61010-1 IEC 60950-1 and IEC 62368-1.
- ▶ Make sure that the power supply pack meets the requirements in accordance with IEC 61010-1 IEC 60950-1 and IEC 62368-1.
- ▶ Where possible, use original power supply packs or only power supply packs that correspond with the applicable safety regulations.

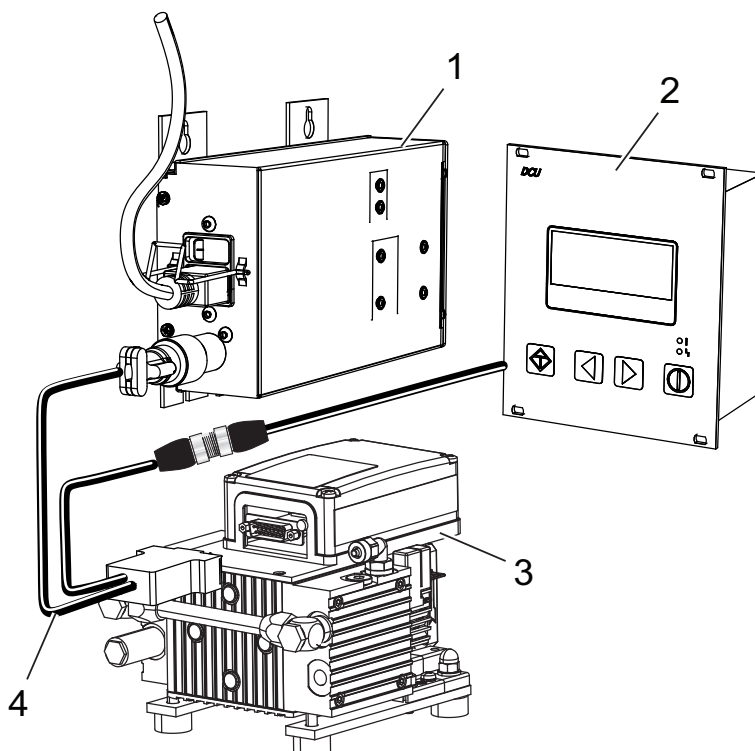

Fig. 4: Connection of the electronic drive unit to the power supply and DCU

- | | |
|-------|--|
| 1 TPS | 3 MVP |
| 2 DCU | 4 Connecting cable, PM 061 350 -T |

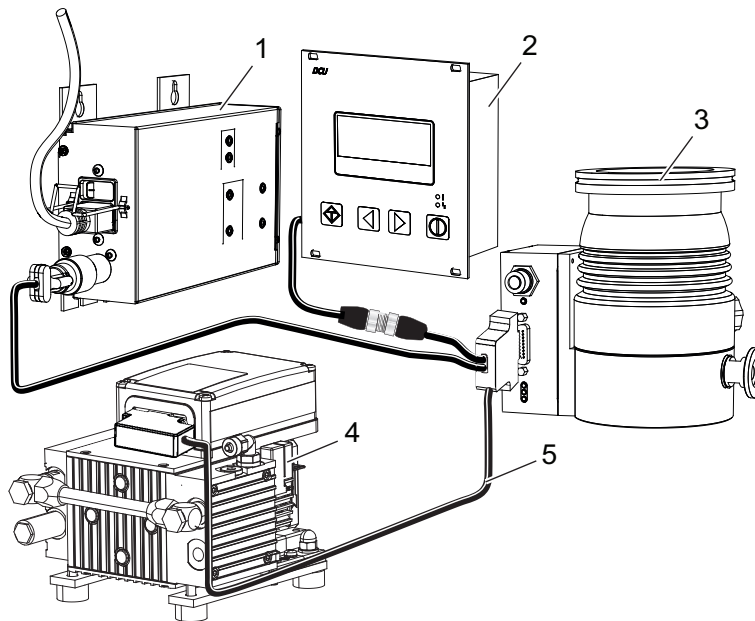

Fig. 5: Connecting the electronic drive unit to the power supply, DCU and turbopump

- | | |
|-------------|-----------------------------------|
| 1 TPS | 4 MVP |
| 2 DCU | 5 Connecting cable, PE 100 013 -T |
| 3 Turbopump | |

Original power supply packs (e.g. TPS 110 or DCU 110) and connection cables are available for electronic drive unit voltage supply.

Connecting the electronic drive unit

1. Ensure the correct supply voltage.
2. Make sure that the "S1" power supply pack master switch is off prior to connection.
3. Plug the 15-pin connection cable plug into the "remote" connection on the electronic drive unit and secure it.
4. Plug the connecting socket with the bayonet catch into the "DC out" connection on the power supply pack and lock it.
5. **When using a display and control unit:** Connect the "RS-485" connector of a suitable connection cable to the display and control unit.

6 Interfaces

6.1 "Remote" interface

NOTICE

Property damage on the electronics

Separating all plug-and-socket connections within the bus system with voltage supply switched on may lead to the destruction of electronic components.

- ▶ Always disconnect the voltage supply before removing the connecting plug.
- ▶ After switching off the power supply pack, wait until the residual load has dispersed completely before disconnecting the plug-and-socket connection.

The 15-pin sub-D connection with the "remote" designation offers the possibility to operate the electronic drive unit via remote control. The following specifications are the factory settings for the electronic drive unit. They can be configured with the Pfeiffer Vacuum parameter set.

- ▶ Utilize the screened plug and cable.

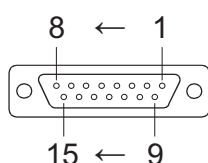

Fig. 6: Pin assignment of the D-Sub socket, 15-pin

Pin	Function	Description, factory setting
1	+24 VDC input	Voltage supply for drive and interface
2	DI access request	V+: Control via DIs, --> GND/open: Control unlocked
3	DI1	V+: Rotation speed setting mode, --> GND/open: no rotation speed setting mode
4	DI2	Only valid for vacuum pumps with a solenoid valve; the following then applies: V+: Valve released, --> GND/open: Valve closed
5	DI pumping station	V+: Vacuum pump on, --> GND/open: Vacuum pump off
6	DI standby	V+: standby, --> GND/open: no standby
7	V+	24 V output
8	DO1	GND: Error, V+: no error
9	DO2	GND: Vacuum pump off, V+: Vacuum pump on
10	n.c.	
11	n.c.	
12	n.c.	
13	RS-485	D+
14	RS-485	D-
15	Ground (GND)	Ground connection of the voltage supply; reference ground for all digital inputs and outputs

Tbl. 5: Plug arrangement of the D-Sub socket, 15-pin

6.1.1 Voltage supply

24 V DC input: The voltage supply is carried out using a connecting cable from the Pfeiffer Vacuum accessories or using a cable provided by the customer.

- **Pin 1:** +24 V DC
- **Pin 15:** Earth (GND)

24 V DC output / pin 7: Inputs 2 to 6 are activated if they are connected to pin 7 (active high) with +24 VDC. They can also be activated via an external SPS. The functions are deactivated by "SPS high level" and by "SPS low level".

- PLC High level: +13 V to +33 V
- PLC Low level: -33 V to +7 V
- Ri: 7 kΩ
- $I_{\max} < 200$ mA

6.1.2 Inputs

The digital inputs switch various electronic drive unit functions. Inputs are assigned with functions ex-factory. You can configure them via the RS-485 interface and the Pfeiffer Vacuum parameter set.

DI remote priority/pin 2

V+: The "remote" connection has control priority over all other control sources.

open: Remote priority "inactive"

DI1 (rotation speed setting mode)/pin 3

V+: Rotation speed setting mode "active"

open: Rotation speed setting mode "inactive"

DI pumping station/pin 5

V+: Vacuum pump on.
Control of all components connected and malfunction acknowledgement.

open: Vacuum pump off

DI stand-by / pin 6

V+: Stand-by activated
The stand-by speed can be selected in the range **30 to 100%** of the nominal speed.

GND/ Stand-by off

open:

6.1.3 Outputs

The digital outputs have a maximum load limit of 24 V/50 mA per output. All outputs listed are configurable with the Pfeiffer Vacuum parameter set via the RS-485 interface (description relates to factory settings).

DO1/Pin 8

V+: No errors
After applying the voltage supply, the digital output DO1 permanently outputs V+ meaning which means "no error".

GND Error
"Active low" signifies "Error" (common error message).

DO2/Pin 9

V+: Vacuum pump on
"Active high" means "Vacuum pump on" and rotates at set rotation speed.
Example: Use the signal for the message vacuum pump "Ready for operation".

GND: Vacuum pump off

6.1.4 RS-485

Pin 13 and pin 14

You can connect a Pfeiffer Vacuum display and control unit (DCU or HPU) or an external PC via pin 13 and pin 14 on the D-sub connection of the electronic drive unit.

6.2 Interface RS-485

⚠ DANGER

Danger to life from electric shock

When establishing the voltages that exceed the specified safety extra-low voltage (according to IEC 60449 and VDE 0100), the insulating measures will be destroyed. There is a danger to life from electric shock at the communication interfaces.

- ▶ Connect only suitable devices to the bus system.

The interface with the designation “RS-485” is intended for the connection of a Pfeiffer Vacuum display and control unit (DCU or HPU) or an external computer. The connections are galvanically safe and are isolated from the maximum supply voltage for the electronic drive unit.

Designation	Value
Serial interface	RS-485
Baud rate	9600 Baud
Data word length	8 bit
Parity	none (no parity)
Start bits	1
Stop bits	1

Tbl. 6: Features of the RS-485 interface

Connecting Pfeiffer Vacuum display and control units or a PC

- ▶ Use connection cables from the control unit scope of delivery or from the accessories program.
- ▶ You can connect one external control unit to the RS-485 interface.
- ▶ You can connect a USB interface (PC) via the USB/RS-485 converter.

Networking as RS-485 bus

The group address of the electronic drive unit is 961.

1. Install the devices according to the specification for RS-485 interfaces.
2. Make sure that all devices connected to the bus have different RS-485 device addresses [P:797].
3. Connect all devices with RS-485 D+ and RS-485 D- to the bus.

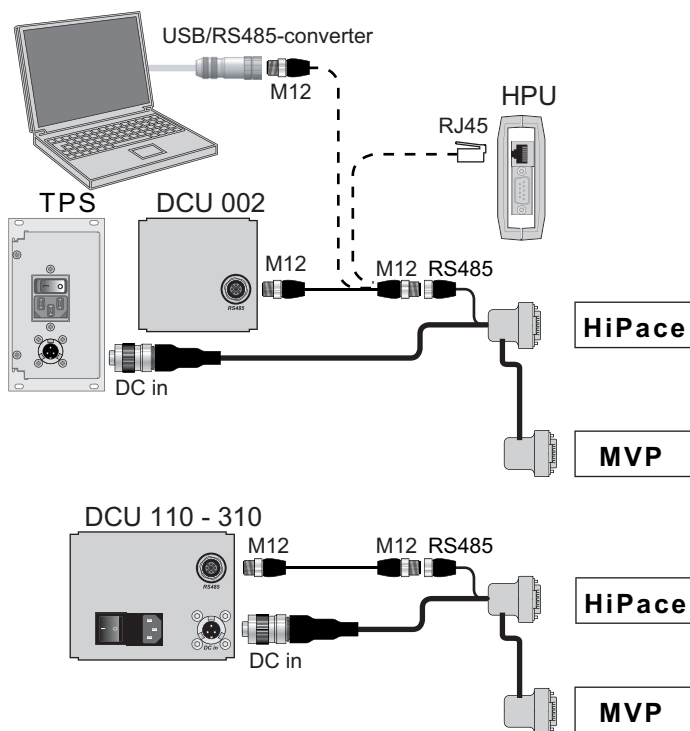

Fig. 7: Connection options via interface RS-485

Connecting Pfeiffer Vacuum display and control units or a PC

One external control unit each can be connected at the RS-485 interface.

1. Use the respective connection cable from the control unit shipment or from the accessories program.
2. Use the option to connect a PC via the USB/RS-485 converter.

6.3 Cross-linked via the RS-485 connection

⚠ DANGER

Danger to life from electric shock

When establishing the voltages that exceed the specified safety extra-low voltage (according to IEC 60449 and VDE 0100), the insulating measures will be destroyed. There is a danger to life from electric shock at the communication interfaces.

- ▶ Connect only suitable devices to the bus system.

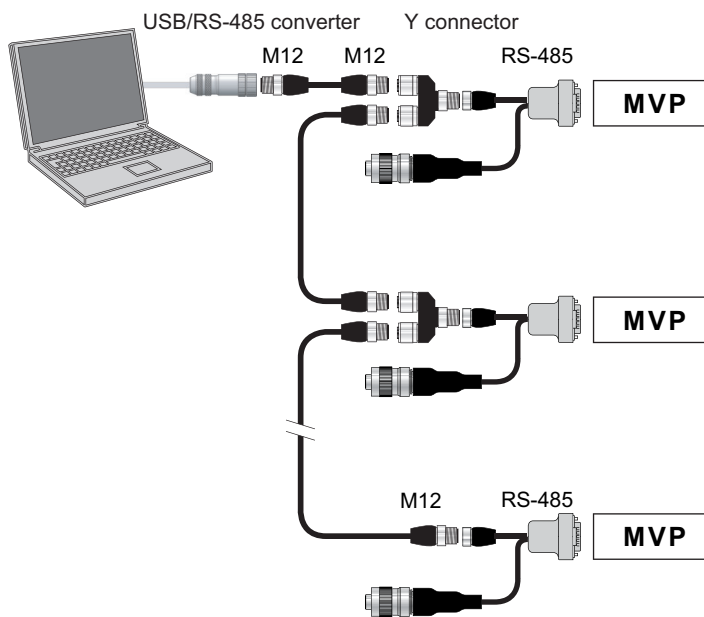

Fig. 8: Networking via the RS-485 interface

6.4 Pfeiffer Vacuum protocol for RS-485 interface

6.4.1 Telegram frame

The telegram frame of the Pfeiffer Vacuum protocol contains only ASCII code characters [32; 127], the exception being the end character of the telegram C_R . Basically, a master (e.g. a PC) sends a telegram, which a slave (e.g. electronic drive unit or gauge) responds to.

a2	a1	a0	*	0	n2	n1	n0	l1	l0	dn	...	d0	c2	c1	c0	C_R
a2 – a0		Unit address for slave														
		<ul style="list-style-type: none"> • Individual address of the unit ["001";"255"] • Group address "9xx" for all identical units (no response) • Global address "000" for all units on the bus (no response) 														
*		Action according to telegram description														
n2 – n0		Pfeiffer Vacuum parameter numbers														
l1 – l0		Data length dn to d0														
dn – d0		Data in the respective data type (see chapter "Data types", page 28).														

c2 – c0	Checksum (sum of ASCII values of cells a2 to d0) modulo 256
C _R	carriage return (ASCII 13)

6.4.2 Telegram description

Data query  -->  ?

a2	a1	a0	0	0	n2	n1	n0	0	2	=	?	c2	c1	c0	C _R
----	----	----	---	---	----	----	----	---	---	---	---	----	----	----	----------------

Control command  -->  !

a2	a1	a0	1	0	n2	n1	n0	l1	l0	dn	...	d0	c2	c1	c0	C _R
----	----	----	---	---	----	----	----	----	----	----	-----	----	----	----	----	----------------

Data response / Control command understood  --> 

a2	a1	a0	1	0	n2	n1	n0	l1	l0	dn	...	d0	c2	c1	c0	C _R
----	----	----	---	---	----	----	----	----	----	----	-----	----	----	----	----	----------------

Error message  --> 



a2	a1	a0	1	0	n2	n1	n0	0	6	N	O	_	D	E	F	c2	c1	c0	C _R
										_	R	A	N	G	E				
										_	L	O	G	I	C				

- NO_DEF Parameter number n2–n0 no longer exists
- _RANGE Data dn–d0 outside the permissible range
- _LOGIC Logical access error

6.4.3 Telegram example 1



Data query

Current rotation speed (parameter **[P:309]**, device address slave: "123")

 -->  ?	1	2	3	0	0	3	0	9	0	2	=	?	1	1	2	C _R
ASCII	49	50	51	48	48	51	48	57	48	50	61	63	49	49	50	13

Data response: 633 Hz



Current rotation speed (parameter **[P:309]**, device address Slave: "123")

 --> 	1	2	3	1	0	3	0	9	0	6	0	0	0	6	3	3	0	3	7	C _R
ASCII	49	50	51	49	48	51	48	57	48	54	48	48	48	54	51	51	48	51	55	13

6.4.4 Telegram example 2



Control command

Switch on the pumping station (parameter **[P:010]**, device address Slave: "042")

 -->  !	0	4	2	1	0	0	1	0	0	6	1	1	1	1	1	1	0	2	0	C _R
ASCII	48	52	50	49	48	48	49	48	48	54	49	49	49	49	49	49	48	50	48	13

Control command understood

Switch on the pumping station (parameter **[P:010]**, device address Slave: "042")

 --> 	0	4	2	1	0	0	1	0	0	6	1	1	1	1	1	1	0	2	0	C _R
ASCII	48	52	50	49	48	48	49	48	48	54	49	49	49	49	49	49	48	50	48	13

6.4.5 Data types

No.	Data type	Description	Length l1 – l0	Example
0	boolean_old	Logical value (false/true)	06	000000 corresponds with false 111111 corresponds with true
1	u_integer	Positive whole number	06	000000 to 999999
2	u_real	Positive fixed point number	06	001571 corresponds with 15.71
3	u_expo	Positive exponential number	06	1.2E-2 corresponds with $1,2 \cdot 10^{-2}$ 005E8 corresponds with $5 \cdot 10^8$
4	string	Any character string with 6 characters. ASCII codes between 32 and 127	06	TC_110, TM_700
6	boolean_new	Logical value (false/true)	01	0 corresponds with false 1 corresponds with true
7	u_short_int	Positive whole number	03	000 to 999
10	u_expo_new	Positive exponential number. The last of both digits are the exponent with a deduction of 20.	06	100023 corresponds with $1,0 \cdot 10^3$ 100000 corresponds with $1,0 \cdot 10^{-20}$
11	string16	Any character string with 16 characters. ASCII codes between 32 and 127	16	this-is-an-example
12	string8	Any character string with 8 characters. ASCII codes between 32 and 127	08	Example

7 Parameter set

7.1 General

All variables of the vacuum pump relevant for the function are stored as parameters in the electronic drive unit. Each parameter has a three-digit number and a description. Parameters can be used via Pfeiffer Vacuum display and control panels or via RS-485 with the Pfeiffer Vacuum protocol.

Conventions

Parameters are printed in bold as **three-digit numbers in square brackets**. The designation can also be specified.

Example: **[P:312] Software version**

Factory settings

The electronic drive unit is pre-programmed in the factory. This makes a more direct and safe operation of the vacuum pump possible without additional configuration.

You can configure the following parameters for the specific process:

- **[P:026]**: rotation speed setting mode on/off.
- **[P:707]**: specification of the rotation speed setting mode with 30 to 170 % of the nominal rotation speed.
- **[P:002]**: stand-by mode on/off.

#	Three digit number of the parameter
Display	Display of parameter description
Description	Brief description of the parameters
Functions	Function description of the parameters
Data type	Type of formatting of the parameter for the use with the Pfeiffer Vacuum protocol
Access type	R (read): Read access; W (write): Write access
Unit	Physical unit of the described variable
min. / max.	Permissible limit values for the entry of a value
default	Factory default pre-setting (partially pump-specific)
	The parameter can be saved persistently in the electronic drive unit

Tbl. 7: Explanation and meaning of the parameters

7.2 Control commands

#	Display	Designations	Functions	Data type	Access type	Unit	min.	max.	default	can be stored
002	Standby	Standby	0 = off 1 = on	0	RW		0	1	0	x
009	ErrorAckn	Malfunction acknowledgement	-	0	W		1	1	-	x
010	PumpgStatn	Pump	0 = off 1 = on	0	RW		0	1	0	x
019	Cfg DO2	Output DO2 configuration	1 = No error 2 = Error 5 = Set rotation speed reached 6 = Pump on 9 = "0" 10 = "1" 11 = Remote priority active	7	RW		0	20	5	x

#	Display	Designations	Functions	Data type	Access type	Unit	min.	max.	default	can be stored
024	Cfg DO1	Output DO1 configuration	Settings, see [P:019]	7	RW		0	20	1	x
026	SpdSet-Mode	Speed actuator operation	0 = off 1 = on	7	RW		0	1	0	x
030	ValveMode	Flushing gas configuration (if present)	0 = auto 1 = closed 2 = open	7	RW		0	2	0	x
050	PurgeGas	Flushing gas (if present)	0 = off 1 = on	0	RW		0	1	1	x
060	CtrlVialnt	Operation of the interface	1 = remote 2 = RS-485 4 = PV.can 255 = Interface selection	7	RW		1	255	1	x
061	IntSelLckd	Interface selection locked	0 = off 1 = on	0	RW		0	1	0	x

Tbl. 8: Parameter set | Control commands

7.3 Status requests

#	Display	Designations	Functions	Data type	Access type	Unit	min.	max.	default	can be stored
303	Error code	Error code		4	R					
309	ActualSpd	Actual rotational speed (Hz)		1	R	Hz				
310	DrvCurrent	Drive current	Drive current in A	2	R	A	0	9999.99		
311	OpHrsPump	Pump operating hours		1	R	h				x
312	Fw version	Software version interface circuit board		4	R					
313	DrvVoltage	Supply voltage	Voltage in V	2	R	V				
314	OpHrsElec	Drive electronics operating hours		1	R	h				x
315	Nominal Spd	Nominal rotation speed (Hz)		1	R	Hz				
316	DrvPower	Drive power	Output in W	1	R	W				
330	TempPump	Pump temperature		1	R	°C	0	999999		
349	ElecName	Device name designation		4	R					
354	HW Version	Hardware version interface circuit board		4	R					
398	ActualSpd	Actual speed (rpm)		1	R	rpm				
399	NominalSpd	Nominal rotation speed (rpm)		1	R	rpm				

Tbl. 9: Parameter set | Status requests

7.4 Reference value inputs

#	Display	Designations	Functions	Data type	Access type	Unit	min.	max.	de-fault	can be stored
707	SpdSVal	Setpoint in speed-control operation	Set rotation speed as % of nominal rotation speed	2	RW	%	30	170	75	x
717	StdbysVal	Rotational speed setpoint in standby operation		2	RW	%	30	100	66.7	x
721	SlgVlvTime	Flushing gas specification active		1	RW	s	5	255	60	x
797	RS485Adr	RS-485 Interface address		1	RW		1	255	2	x

Tbl. 10: Parameter set | Reference value inputs

7.5 Additional parameter for the DCU



Additional parameter in the control panel

The basic parameter set is set in the electronic drive unit ex-factory. For controlling connected external components (e.g. vacuum measuring instruments), additional parameters (extended parameter set) are available in the corresponding Pfeiffer Vacuum display and control panels.

- Refer to the corresponding operating instructions of the respective components.
- Select the extended parameter set with parameter **[P:794] = 1**.

#	Display	Description	Functions	Data type	Access type	Unit	min.	max.	de-fault	
340	Pressure	Actual pressure value (ActiveLine)		7	R	hPa	$1 \cdot 10^{-10}$	$1 \cdot 10^3$		
350	Ctr Name	Display and control panel: type		4	R					
351	Ctr Software	Display and control panel: software version		4	R					
738	Gauge type	Type of pressure gauge		4	RW					
794	Param set	Parameter set	0 = Basic parameter set 1 = Extended parameter set	7	RW		0	1	0	
795	Servicelin	Insert service line		7	RW				795	

Tbl. 11: Parameter for DCU functions

8 Operation

8.1 Putting the vacuum pump into operation

Important settings and function-related variables are factory-programmed into the vacuum pump electronic drive unit as parameters. Each parameter has a three-digit number and a description. Parameter-driven operation and control is supported via Pfeiffer Vacuum displays and control units, or externally via RS-485 using Pfeiffer Vacuum protocol.

WARNING

Danger of poisoning due to toxic process media escaping from the exhaust pipe

During operation with no exhaust line, the vacuum pump allows exhaust gases and vapors to escape freely into the air. There is a risk of injury and fatality due to poisoning in processes with toxic process media.

- ▶ Observe the pertinent regulations for handling toxic process media.
- ▶ Safely purge toxic process media via an exhaust line.
- ▶ Use appropriate filter equipment to separate toxic process media.

NOTICE

Vacuum pump damage caused by overpressure

Mixing up the connections causes overpressure overload. The vacuum pump can be started only against max. 1 bar differential pressure between inlet and outlet; otherwise the motor jams and sustains damage.

- ▶ Make sure that the distributor is installed correctly on the diaphragm heads, before connecting the vacuum pump to the vacuum equipment.
- ▶ Before commissioning, make completely sure that the pressure side pressure is below the permissible limit.

Parameter	Name	Designation	Adjustment, setting
[P:707]	SpdSVal	Speed-control operation specification	75 %

Tbl. 12: Factory setting of the electronic drive unit for diaphragm pumps when delivered

Procedure

1. Compare the frequency specifications on the rating plate with the available supply voltage.
2. Check the exhaust connection for free passage (max. permissible pressure: 1100 hPa absolute).
3. Actuate the shut-off units so that the shut-off units open before or at the same time as the vacuum pump starts up.

8.2 Switching on the vacuum pump

When pumping down dry gases, no special precautions are required.

CAUTION

Danger of burns on hot surfaces

Depending on the operating and ambient conditions, the surface temperature of the vacuum pump can increase to above 70 °C.

- ▶ Provide suitable touch protection.



Warm-up time of the vacuum pump

The warm-up time depends on the ambient temperature and takes at least 30 minutes.

Prerequisite

- required cable connections established

Switching on the vacuum pump

1. If required, switch the vacuum pump on in each pressure range in one of the 3 possible ways:
 - using a mains switch on the power supply pack with respective bridges on the 15-pin D-Sub socket
 - via the peripheral devices DCU/HPU
 - using the PLC control unit on the 15-pin D-Sub socket
2. Allow the vacuum pump to warm up prior to process start, with the vacuum connection closed.

The vacuum pump achieves the specified throughput and final pressure values once the operating temperature has been reached.

8.3 Operating the diaphragm pump with gas ballast

⚠ WARNING

Explosion hazard from reactive, potentially explosive or other hazardous gas/air mixtures

Uncontrolled inlet of gas at the gas ballast valve leads to sparks generated mechanically following diaphragm rupture, hot surfaces or to potentially explosive gas/air mixtures in the vacuum system caused by static electricity.

- ▶ If necessary, use inert gas for supplying the flushing gas in order to avoid a potential ignition.

⚠ WARNING

Risk of poisoning due to toxic process gases escaping

For intake pressures > 500 hPa, process gas may escape from the open gas ballast valve. There is a risk of injury and fatality due to poisoning in processes with toxic process media.

- ▶ If necessary, use inert gas to avoid potential contamination.
- ▶ If necessary, use an extraction line.

NOTICE

Risk of damage from condensation in vacuum pump

During operation without gas ballast, condensation may form as a result of the vapor compatibility of the vacuum pump being exceeded.

- ▶ Pump condensable vapors only when the vacuum pump is warm and the gas ballast valve open.
- ▶ Allow the vacuum pump to run on after process end for another 30 minutes with the gas ballast valve open.
 - This protects the vacuum pump against corrosion.

Vapors or moisture from pumped media impair the throughput after condensation in the vacuum pump.

Behavior with process gases with condensable vapors

- ▶ Operate the vacuum pump with gas ballast, i.e. with the gas ballast valve open.

8.4 Configuring the connections with the Pfeiffer Vacuum parameter set

The electronic drive unit is pre-configured with the factory default basic functions and is ready for operation. For individual requirements, you can configure most connections for the electronic drive unit with the parameter set.

8.4.1 Configuring the digital outputs

Option	Description
1 = No error	active, with trouble-free operation
2 = Error	active, if the error message is active
5 = Set rotation speed reached	active, once the set rotation speed is reached
6 = Pump on	active, if pump on, motor on and no error
9 = always 0	GND for the control of an external device

Option	Description
10 = always 1	V+ for the control of an external device
11 = Remote	active, if the remote priority is active

Tbl. 13: Configure parameters [P:019] and [P:024]

Procedure

- ▶ Perform the configuration according to the table.

8.4.2 Selecting the interfaces

Option [P:060]	Description
1 = remote	Operation via connection "remote"
2 = RS-485	Operation via connection "RS-485"
4 = PV.can	For service purposes only
Option [P:061]	
0 = off	Interface selection can be set via [P:060].
1 = on	Interface selection locked

Tbl. 14: Parameters [P:060] and [P:061]

Procedure

- ▶ Select the interface according to the table.

8.5 Operating modes

The following operating modes are possible:

- Operation without control unit
- Operation via an external control unit
- Operation via RS-485 and Pfeiffer Vacuum display and control unit or PC

The connection of a Pfeiffer Vacuum display and control panel permits the controlling of the vacuum pump via the parameters fixed in the electronic drive unit.



Automatic start

After bypassing the contacts at pins 2, 7, 5 on the connecting plug or when using a connecting cable with respective bridges and applying the supply voltage, the vacuum pump starts up immediately.

Pfeiffer Vacuum therefore recommends switching on the voltage supply immediately before operation.

Operate without control unit

1. Connect the respective connecting cable with bridges to the power supply plug of the electronic drive unit.
2. Provide the current supply for the power supply pack.
3. Switch on the power supply pack with switch S1.

After applying the operating voltage, the vacuum pump carries out a self-test to check the supply voltage. After a successfully completed self-test, the vacuum pump starts.

Operate via the external control

- ▶ Connect the remote control via the 15-pin D-Sub socket.

The control is carried out by means of "PLC level".

Operate with peripheral devices DCU or HPU.

1. When handling the Pfeiffer Vacuum display and control unit, observe the associated operating instructions:
 - "DCU" operating instructions available from the [Download Center](#).
 - "HPU" operating instructions available from the [Download Center](#).
2. Connect the respective peripheral device to the 15-pin D-Sub socket.

3. Switch on the power supply pack with switch S1 or on the peripheral device.
4. Make the desired settings via the RS-485 using the peripheral device.

8.5.1 Normal operation

If the gas ballast valve is permanently open or closed ([P:050] = 0 or [P:030] = 1 or 2) the vacuum pump starts up in boost mode for max. 5 min. at the maximum speed. The current is monitored at the same time. If the current is below a threshold value, the speed is controlled down to nominal rotation speed. In case the power input increases again, automatic increase of the speed does not take place. An increase in speed is reached again after vacuum pump stop/start.

In automatic mode of the gas ballast valve ([P:050] = 1 and [P:030] = 0) the vacuum pump starts up in boost mode for 15 min. constant and then automatically drops back to the nominal speed.

Setting the related parameters

1. Set the parameter [P:002] to "0".
2. Set the parameter [P:026] to "0".
3. Set the parameter [P:050] to the desired value.
4. Set the parameter [P:030] to the desired value.
5. Check the set rotation speed (parameter [P:309] or [P:398]).

8.5.2 Stand-by operation

Pfeiffer Vacuum recommends stand-by operation for the vacuum pump during breaks in processes or production.

- The factory setting is 66.7 % of the nominal speed.
- Stand-by operation has priority over rotation speed setting mode.
- With active stand-by mode, the electronic drive unit reduces the speed of the vacuum pump in the range of **30 to 100%** of the nominal speed.

Activate stand-by rotation speed

1. Set the parameter [P:717] to the required value in %.
2. Set the parameter [P:026] to "0".
3. Set the parameter [P:002] to "1".
4. Check the set rotation speed (parameter [P:309] or [P:398]).

8.5.3 Speed actuator operation



Permissible rotation speed range of the vacuum pump

Parameterization in rotation speed setting mode is subject to the permissible rotation speed range of the respective vacuum pump. The electronic drive unit regulates automatically to the next valid value.

The set rotation speed is selected via the parameter [P:707] in the range **30 to 170 %** of the set rotation speed. As of a speed higher than the set rotation speed (> 100%), increased pump wear is possible.

The rotation speed setting mode has priority over the stand-by mode.

Set the rotation speed setting mode

1. Set the parameter [P:707] to the required value in %.
2. Set the parameter [P:026] to "1".
3. Query the set rotation speed via parameter [P:309] or [P:398].

8.5.4 Gas ballast valve control

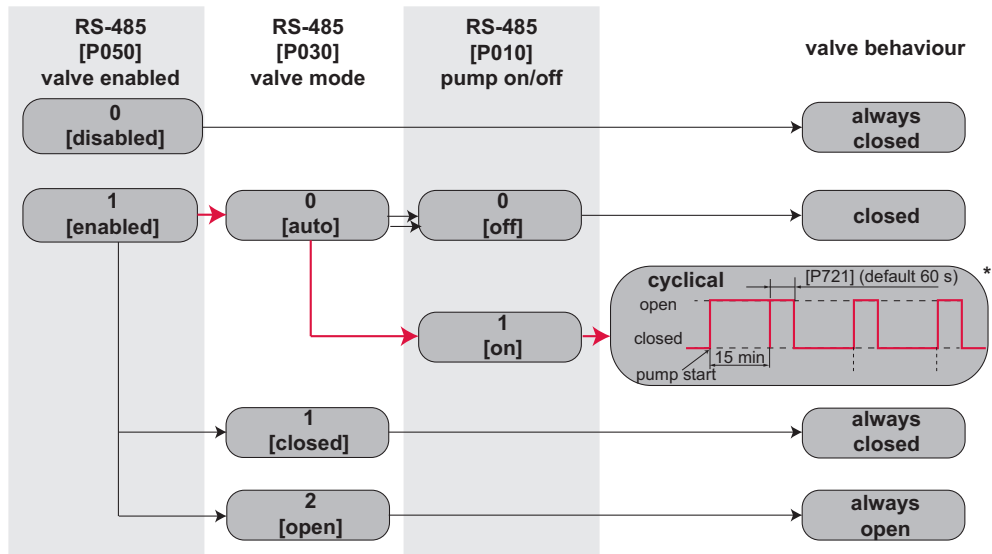

Fig. 9: Gas ballast valve control diagram

If the gas ballast valve control is open, [P:030] defines the valve mode. In automatic mode (pre-set ex factory), the valve opens once only for 15 min whenever the pump starts; it then opens cyclically for 5 to 255 s every 15 min (set using [P:721]). The gas ballast valve also opens when you stop stand-by operation or speed setting mode.

8.6 Operation monitoring

8.6.1 Operating mode display via LED

The LED on the electronic drive unit indicates the basic operating conditions. A differentiated malfunction and warning display is possible only for operation with DCU or HPU.

Display	Activity	Meaning
██████████	None	<ul style="list-style-type: none"> No adequate power supply
▣█████████	10% active, 1 Hz	<ul style="list-style-type: none"> No errors Vacuum pump "OFF" Vacuum pump stationary
▣▣███████	50 % active, 1 Hz	<ul style="list-style-type: none"> No errors Vacuum pump "OFF" Vacuum pump still rotating
█████████▣	90 % active, 1 Hz	<ul style="list-style-type: none"> No errors Vacuum pump "ON" Set rotation speed not reached
▣▣▣▣▣▣▣▣	100% active	<ul style="list-style-type: none"> No errors Vacuum pump "ON" Target speed reached
▣▣▣▣▣▣▣▣▣▣▣▣▣▣	50% active, 10, Hz	<ul style="list-style-type: none"> Defect

Tbl. 15: Behavior and meaning of the LED of the electronic drive unit

8.6.2 Temperature monitoring



If threshold values are exceeded, output signals from temperature sensors allow the vacuum pump to be switched to a safe state. Depending on the type, temperature thresholds for warning and malfunction messages are stored immutably in the electronic drive unit. For information purposes, various status requests are set up in the parameter set.

- With a pump temperature $T > 75\text{ °C}$, the electronic drive unit reduces the motor to the nominal rotation speed to avoid overheating of the vacuum pump.
 - **"Warning"** is displayed.
 - After cooling down ($< 72\text{ °C}$), the vacuum pump starts to run at set rotation speed.
- If the error threshold for excess temperature $T > 85\text{ °C}$ is exceeded, the vacuum pump switches off immediately.
 - A **"Malfunction message"** is displayed.

Acknowledge the malfunction

- ▶ Remove the cause of the fault.
- ▶ Switch the vacuum pump off and back on.

As an alternative, acknowledge the malfunction via Pfeiffer Vacuum display and control unit

- ▶ Set the parameter **[P:010]** to the value "0/1".
- ▶ Reset the error message with parameter **[P:009]** or by pressing the button  on the DCU.
- ▶ Switch the running vacuum pump off and back on again by pressing the  on the DCU once.

8.7 Switching off the vacuum pump

Procedure

1. Allow the vacuum pump to run on for 5 to 10 minutes with the vacuum connection open to allow any condensate that may be present to be removed from the vacuum pump.
2. If required, switch the vacuum pump off in each pressure range.
3. Disconnect the voltage supply on the power supply pack.

9 Maintenance

9.1 Maintenance instructions

⚠ WARNING

Health hazard through poisoning from toxic contaminated components or devices

Toxic process media result in contamination of devices or parts of them. During maintenance work, there is a risk to health from contact with these poisonous substances. Illegal disposal of toxic substances causes environmental damage.

- ▶ Take suitable safety precautions and prevent health hazards or environmental pollution by toxic process media.
- ▶ Decontaminate affected parts before carrying out maintenance work.
- ▶ Wear protective equipment.

⚠ CAUTION

Danger of injury from moving parts

After a power failure or a standstill as a result of overheating, the motor restarts automatically. There is a risk of injury to fingers and hands if they enter the operating range of rotating parts.

- ▶ Safely disconnect motor from the mains.
- ▶ Secure the motor against reactivation.
- ▶ Dismantle the vacuum pump for inspection, away from the system if necessary.

NOTICE

Damage caused by unsuitable cleaning agents

Unsuitable cleaning agents damage pump parts.

- ▶ Use only approved cleaning agents to clean pump parts.
- ▶ Use only a clean dry cloth to clean the diaphragms and valves.
- ▶ Do not use any alcohol or other cleaning agents to clean the diaphragms and valves.

NOTICE

Danger of property damage from improper maintenance

Unprofessional work on the vacuum pump will lead to damage for which Pfeiffer Vacuum accepts no liability.

- ▶ We recommend taking advantage of our service training offering.
- ▶ When ordering spare parts, specify the information on the nameplate.

The following section relates to the tasks for cleaning and maintaining the vacuum pump. Valves and diaphragms are wear parts.

Component	Operating hours
Diaphragms	15 000
Valves	15 000

Tbl. 16: Typical service life with normal use

Prerequisites

- Vacuum pump switched off
- Vacuum pump vented from atmospheric pressure
- Vacuum pump cooled

Required materials

- Cloth (clean, lint-free)
- Water or mild soap solution

Servicing the vacuum pump

1. Disconnect the vacuum pump from the voltage supply.
2. Secure the motor against reactivation.
3. Remove any external contamination on the vacuum pump with cloth slightly moistened with water or a mild soap solution.
4. Allow all cleaned parts to dry well.
5. For maintenance work, only dismantle the vacuum pump to the extend needed.
6. Clean the suction chamber, diaphragms, and valves with a dry cloth.
7. Examine the diaphragms and valves for cracks at the latest when the pressure values achieved decrease.

9.2 Checklist for inspection and maintenance



Notes on maintenance intervals

Depending on the process, the required maintenance intervals may be shorter than the reference values specified in the table.

- Consult with Pfeiffer Vacuum Service about shorter maintenance intervals for extreme loads or for specific processes.



Maintenance level 2

We recommend that Pfeiffer Vacuum Service carry out maintenance work at level 2. If the specified intervals are exceeded, or if maintenance work is carried out improperly, no warranty or liability claims are accepted on the part of Pfeiffer Vacuum. This also applies wherever parts other than original spare parts are used.

Action	Inspection	Maintenance level 1	Maintenance level 3	Required material
Interval	as required; at least once every six months	as required; at least every 2 years	as required; at least every 4 years	
Check silencer for contamination ²⁾	■			
Test vacuum pump optically and acoustically	■			
Read out and analyze pump data		■		
Clean the vacuum pump		■		
Change the diaphragms and valves		■		Overhaul kit
Change silencer ³⁾		■		Silencer
Perform a functional test		■		
Incoming inspection with vibration measurement			■	
Disassemble vacuum pump completely			■	
Clean vacuum pump completely			■	
Change gas ballast filter ⁴⁾			■	Filter
Replace all wear parts			■	Diaphragms, valves, sealing rings, silencers

Tbl. 17: Maintenance intervals

2) if present

3) if present

4) if present

9.3 Change the diaphragms and valves

NOTICE

Property damage from incorrect installation

Change in dead volume due to incorrect installation of the original spacer disks impairs the final vacuum or leads to bearing damage.

- ▶ During disassembly, keep the existing spacer disks separate per installation location.
- ▶ Reinstall the same number of original spacer disks per diaphragm head.

9.3.1 Dismantle the diaphragm head and valves

Required tools

- Open-end wrench, **WAF 14**
- Allen key, **WAF 4**

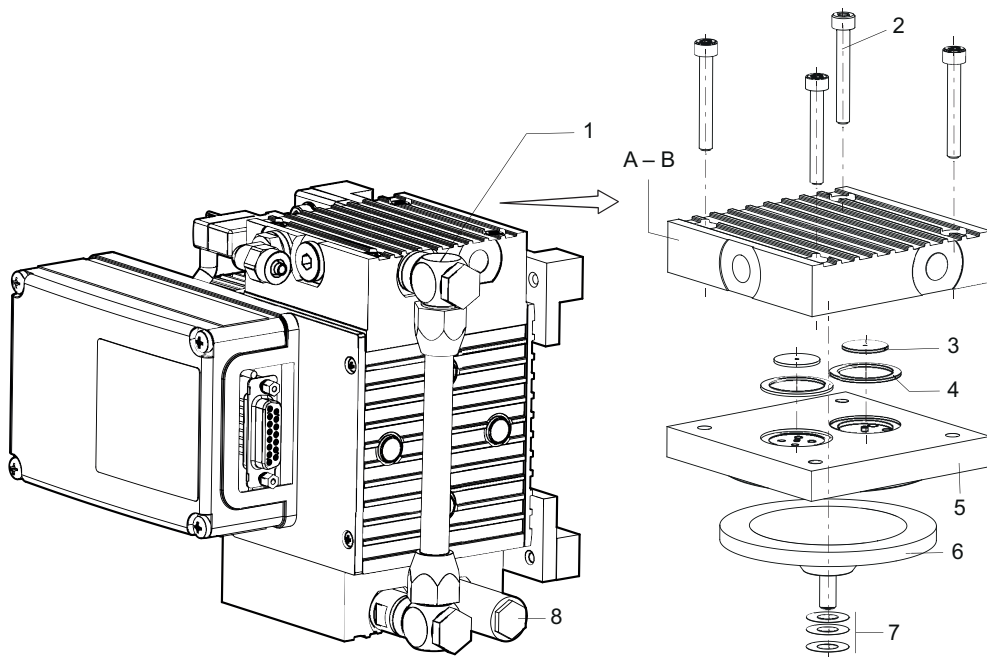

Fig. 10: Diaphragm head and valves

A – B	Diaphragm head cover	5	Intermediate plate
1	Banjo bolt	6	Diaphragm
2	Cylinder screws	7	Spacer disks
3	Valve plate	8	Silencer
4	Sealing ring (only on diaphragm head A)		

Procedure

1. Remove the banjo bolts and dismantle the hose connection.
2. Rotate the diaphragm pump so that the diaphragm head to be dismantled is facing upwards.
3. Unscrew cylinder screws from the diaphragm head.
4. Remove the diaphragm head.
 - Observe the sealing ring on the intake side.
5. Remove the intermediate plate.
6. Release the valves and the sealing ring from the intermediate plate.
7. Lift the diaphragm slightly at the side.
8. Unscrew and remove the diaphragm from the connection rod by hand.
 - The diaphragm has a right-hand thread.
 - Pay attention to the spacer disks.

9.3.2 Cleaning and replacing the diaphragms and valves

Prerequisite

- Diaphragm and valves removed

Required spare parts

- Overhaul kit

Required consumables

- Clean, dry cloth
- Isopropanol

Procedure

1. Clean diaphragms and valves with a clean, dry cloth.
 - Do not use isopropanol or other cleaning agents to clean diaphragms and valves.
2. Clean valve seats, intermediate plate and head cover with isopropanol.
3. Check valve seats, intermediate plate and head cover for wear.
4. Replace all wear parts according to the inspection sets.

9.3.3 Mount the diaphragm head and valves



Spacer disks

Spacer disks are available in 3 sizes:

- 13.0 × 6.4 × 0.5 mm
- 13.0 × 6.4 × 0.1 mm
- 16.0 × 6.4 × 0.05 mm

The number and size of the spacer disks vary between the diaphragm heads.

Install the same number and size of original spacer disks per diaphragm head.

Required tools

- Open-end wrench, **WAF 14**
- Allen key, **WAF 4**

Procedure

1. Rotate the diaphragm pump so that the diaphragm head to be mounted is facing upwards.
2. Screw the diaphragm into the connection rod by hand.
 - The diaphragm has a right-hand thread.
 - Pay attention to the spacer disks.
3. Place the valves and the sealing ring in the intermediate plate.
4. Position the intermediate plate.
5. Put on the diaphragm head cover.
 - Observe the sealing ring on the intake side.
6. Screw the screws into the diaphragm head cover.
7. Mount the hose connection using the banjo bolts.

10 Decommissioning

Before shutting down the vacuum pump, observe the following instructions to adequately protect the interior of the vacuum pump (suction chamber) from corrosion:

Procedure for temporary vacuum pump shutdowns

1. Allow the vacuum pump to run on for 5 to 10 minutes with the vacuum connection open to allow any condensate that may be present to be removed from the vacuum pump.
2. If media has entered the vacuum pump that may attack the pump materials or lead to deposits, clean the inside of the pump heads.

Procedure for longer vacuum pump shutdowns

1. Disconnect the vacuum pump from the vacuum system.
2. Remove the vacuum pump from the vacuum system if necessary.
3. Seal the vacuum connection with the original sealing plugs.
4. Store the vacuum pump in dry, dust-free rooms, within the specified ambient conditions.
5. Pack the vacuum pump together with a drying agent in a plastic bag, and seal the vacuum pump airtight if it is to be stored in rooms with damp or aggressive atmospheres.

11 Recycling and disposal

⚠ WARNING

Health hazard through poisoning from toxic contaminated components or devices

Toxic process media result in contamination of devices or parts of them. During maintenance work, there is a risk to health from contact with these poisonous substances. Illegal disposal of toxic substances causes environmental damage.

- ▶ Take suitable safety precautions and prevent health hazards or environmental pollution by toxic process media.
- ▶ Decontaminate affected parts before carrying out maintenance work.
- ▶ Wear protective equipment.



Environmental protection

You **must** dispose of the product and its components in accordance with all applicable regulations for protecting people, the environment and nature.

- Help to reduce the wastage of natural resources.
- Prevent contamination.



Environmental protection

The product and its components **must be disposed of in accordance with the applicable regulations relating to environmental protection and human health**, with a view to reducing natural resource wastage and preventing pollution.

11.1 General disposal information

Pfeiffer Vacuum products contain materials that you must recycle.

- ▶ Dispose of our products according to the following:
 - Iron
 - Aluminium
 - Copper
 - Synthetic
 - Electronic components
 - Oil and fat, solvent-free
- ▶ Observe the special precautionary measures when disposing of:
 - Fluoroelastomers (FKM)
 - Potentially contaminated components that come into contact with media

11.2 Dispose of diaphragm pumps

Pfeiffer Vacuum diaphragm pumps contain materials that you must recycle.

1. Disconnect the electronic drive unit.
2. Dismantle the motor.
3. Decontaminate the components that come into contact with process gases.
4. Separate the components into recyclable materials.
5. Recycle the non-contaminated components.
6. Dispose of the product or components in a safe manner according to locally applicable regulations.

12 Malfunctions

12.1 General

⚠ CAUTION

Danger of injury from moving parts

After a power failure or a standstill as a result of overheating, the motor restarts automatically. There is a risk of injury to fingers and hands if they enter the operating range of rotating parts.

- ▶ Safely disconnect motor from the mains.
- ▶ Secure the motor against reactivation.
- ▶ Dismantle the vacuum pump for inspection, away from the system if necessary.

⚠ CAUTION

Danger of burns on hot surfaces

In the event of a fault, the surface temperature of the vacuum pump can increase to above 70 °C.

- ▶ Allow the vacuum pump to cool down before carrying out any work.
- ▶ Wear personal protective equipment if necessary.

NOTICE

Danger of property damage from improper maintenance

Unprofessional work on the vacuum pump will lead to damage for which Pfeiffer Vacuum accepts no liability.

- ▶ We recommend taking advantage of our service training offering.
- ▶ When ordering spare parts, specify the information on the nameplate.

Vacuum pump and electronic drive unit malfunctions always result in a warning or error message. In both cases, you will receive an error code that you can read out via the interface of the electronic drive unit. If an error occurs, the vacuum pump switches off.

Should malfunctions occur, you can find information about potential causes and how to fix them here:

Problem	Possible causes	Remedy
Vacuum pump will not start up	<ul style="list-style-type: none"> ● No supply voltage or voltage does not correspond to the motor data 	<ul style="list-style-type: none"> ● Check the supply voltage.
	<ul style="list-style-type: none"> ● Pump temperature too low 	<ul style="list-style-type: none"> ● Heat the vacuum pump to a temperature of > 5 °C.
	<ul style="list-style-type: none"> ● Thermal protection of the motor has triggered 	<ul style="list-style-type: none"> ● Identify and eliminate the cause and allow vacuum pump to cool if necessary.
	<ul style="list-style-type: none"> ● Diaphragms or valves dirty 	<ul style="list-style-type: none"> ● Clean the vacuum pump.
	<ul style="list-style-type: none"> ● Overpressure in the exhaust line 	<ul style="list-style-type: none"> ● If required, check and clean the exhaust line.
Vacuum pump switches off after a while after being started	<ul style="list-style-type: none"> ● Thermal protection of the motor has triggered 	<ul style="list-style-type: none"> ● Identify and eliminate the cause and allow vacuum pump to cool if necessary.
	<ul style="list-style-type: none"> ● Exhaust pressure too high 	<ul style="list-style-type: none"> ● Check exhaust line outlet opening and exhaust side accessories.

Problem	Possible causes	Remedy
Vacuum pump does not reach the specified final pressure	<ul style="list-style-type: none"> Condensate in the vacuum pump 	<ul style="list-style-type: none"> Operate the vacuum pump over a longer period at atmospheric pressure and, if necessary, with the gas ballast valve open.
	<ul style="list-style-type: none"> Gas ballast valve open 	<ul style="list-style-type: none"> Close the gas ballast valve.
	<ul style="list-style-type: none"> Soiled valves or diaphragms 	<ul style="list-style-type: none"> If necessary, clean or replace the valves and diaphragms.
	<ul style="list-style-type: none"> Leak in system 	<ul style="list-style-type: none"> Locate and eliminate the leak.
Pumping speed of vacuum pump too low	<ul style="list-style-type: none"> Intake line not well-dimensioned 	<ul style="list-style-type: none"> Make sure that connections are short and cross sections adequately dimensioned.
	<ul style="list-style-type: none"> Exhaust pressure too high 	<ul style="list-style-type: none"> Check exhaust line outlet opening and exhaust side accessories.
Unusual noises during operation	<ul style="list-style-type: none"> Defective valves or diaphragms 	<ul style="list-style-type: none"> If necessary, clean or replace the valves and diaphragms.
	<ul style="list-style-type: none"> Suction chamber dirty. 	<ul style="list-style-type: none"> Clean suction chamber.
	<ul style="list-style-type: none"> Silencer loose or missing. 	<ul style="list-style-type: none"> If necessary, check or replace the silencer.
	<ul style="list-style-type: none"> Valves dirty or defective 	<ul style="list-style-type: none"> If necessary, clean or replace the valves and diaphragms.
	<ul style="list-style-type: none"> Connection rod or motor bearing defective 	<ul style="list-style-type: none"> Call in Pfeiffer Vacuum Service.

Tbl. 18: Troubleshooting on diaphragm pumps

12.2 Error codes

Errors (** Error E—— **) always cause the vacuum pump to be switched off.

Warnings (* Warning F —— *) do not cause the vacuum pump to be switched off.

Handle malfunction messages

1. Read out error codes via Pfeiffer display and control units or a PC.
2. Remove the cause of the malfunction.
3. Reset the malfunction message with parameter **[P:009]**.
 - Use preconfigured quick keys with the symbol  or display tiles on Pfeiffer Vacuum display and control units.

Error code	Problem	Possible causes	Remedy
Err042	Inconsistent software	Checksum errors	<ul style="list-style-type: none"> Contact Pfeiffer Vacuum Service.
Err091	Unknown hardware	-	<ul style="list-style-type: none"> Contact Pfeiffer Vacuum Service.
Err098	Internal communication error between interface board and drive	–	<ul style="list-style-type: none"> Contact Pfeiffer Vacuum Service.
Err117	Vacuum pump excess temperature (> 85 °C)	Insufficient cooling	<ul style="list-style-type: none"> Improve the cooling Check the operating conditions
Err173	Pump overflow	-	<ul style="list-style-type: none"> Contact Pfeiffer Vacuum Service.
Err174	Vacuum pump blocked	–	<ul style="list-style-type: none"> Contact Pfeiffer Vacuum Service.

Tbl. 19: Error messages for vacuum pump

Error code	Problem	Possible causes	Remedy
Wrn117	High temperature vacuum pump (> 75 °C)	<ul style="list-style-type: none"> Insufficient cooling 	<ul style="list-style-type: none"> Improve the cooling Check the operating conditions

Tbl. 20: Warning messages for vacuum pump

12.3 Warning and error messages when operating with DCU

Besides the device-specific warning and error messages on the electronic drive unit, additional messages are displayed with the connected display and control panel.

Display in DCU	Problem	Possible causes	Remedy
* Warning F110 *	Pressure gauge	<ul style="list-style-type: none"> Pressure gauge faulty Connection to the pressure gauge disconnected during operation 	<ul style="list-style-type: none"> Check the cable connection Carry out a restart with pressure gauge connected Replace the pressure gauge completely
** Error E040 **	Hardware error	<ul style="list-style-type: none"> external RAM faulty 	<ul style="list-style-type: none"> Contact Pfeiffer Vacuum Service.
** Error E042 **	Hardware error	<ul style="list-style-type: none"> EPROM checksum incorrect 	<ul style="list-style-type: none"> Contact Pfeiffer Vacuum Service.
** Error E043 **	Hardware error	<ul style="list-style-type: none"> E²PROM write error 	<ul style="list-style-type: none"> Contact Pfeiffer Vacuum Service.
** Error E090 **	Internal device error	<ul style="list-style-type: none"> RAM not large enough DCU is connected to incorrect electronic drive unit 	<ul style="list-style-type: none"> Contact Pfeiffer Vacuum Service. Connect the DCU to the correct electronic drive unit
** Error E698 **	Communication error	<ul style="list-style-type: none"> Electronic drive unit is not responding 	<ul style="list-style-type: none"> Contact Pfeiffer Vacuum Service.

Tbl. 21: Warning and error messages when using a DCU

13 Service solutions by Pfeiffer Vacuum

We offer first-class service

High vacuum component service life, in combination with low downtime, are clear expectations that you place on us. We meet your needs with efficient products and outstanding service.

We are always focused on perfecting our core competence – servicing of vacuum components. Once you have purchased a product from Pfeiffer Vacuum, our service is far from over. This is often exactly where service begins. Obviously, in proven Pfeiffer Vacuum quality.

Our professional sales and service employees are available to provide you with reliable assistance, worldwide. Pfeiffer Vacuum offers an entire range of services, from [original replacement parts](#) to [service contracts](#).

Make use of Pfeiffer Vacuum service

Whether preventive, on-site service carried out by our field service, fast replacement with mint condition replacement products, or repair carried out in a [Service Center](#) near you – you have various options for maintaining your equipment availability. You can find more detailed information and addresses on our homepage, in the [Pfeiffer Vacuum Service](#) section.

You can obtain advice on the optimal solution for you, from your [Pfeiffer Vacuum representative](#).

For fast and smooth service process handling, we recommend the following:



1. Download the up-to-date form templates.
 - [Explanations of service requests](#)
 - [Service requests](#)
 - [Contamination declaration](#)



- a) Remove and store all accessories (all external parts, such as valves, protective screens, etc.).
 - b) If necessary, drain operating fluid/lubricant.
 - c) If necessary, drain coolant.
2. Complete the service request and contamination declaration.



3. Send the forms by email, fax, or post to your local [Service Center](#).



4. You will receive an acknowledgment from Pfeiffer Vacuum.

PFEIFFER VACUUM

Submission of contaminated products

No microbiological, explosive, or radiologically contaminated products will be accepted. Where products are contaminated, or the contamination declaration is missing, Pfeiffer Vacuum will contact you before starting service work. Depending on the product and degree of pollution, **additional decontamination costs** may be incurred.

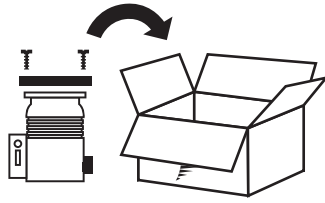

5. Prepare the product for transport in accordance with the provisions in the contamination declaration.
 - a) Neutralize the product with nitrogen or dry air.
 - b) Seal all openings with blind flanges, so that they are airtight.
 - c) Shrink-wrap the product in suitable protective foil.
 - d) Package the product in suitable, stable transport containers only.
 - e) Maintain applicable transport conditions.

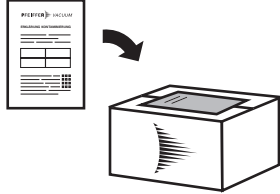

6. Attach the contamination declaration to the **outside** of the packaging.

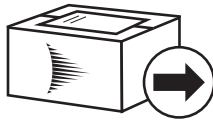

7. Now send your product to your local Service Center.

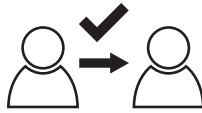

8. You will receive an acknowledgment/quotation, from Pfeiffer Vacuum.

PFEIFFER VACUUM

Our sales and delivery conditions and repair and maintenance conditions for vacuum devices and components apply to all service orders.

14 Spare parts packages

Ordering spare part packages

- ▶ Have the vacuum pump part number to hand, along with other details from the rating plate if necessary.
- ▶ Install original spare parts only.
- ▶ When ordering the inspection set, observe the respective part number of the diaphragm pump.

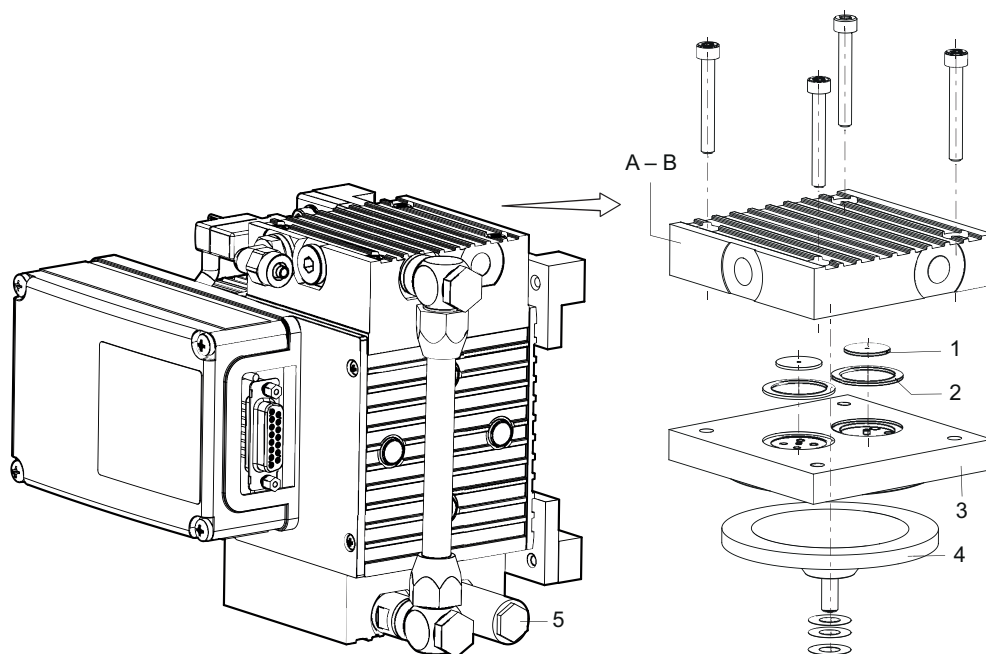

Fig. 11: Spare parts

A – B	Head cover	3	Intermediate plate
1	Valve plate	4	Diaphragm
2	Sealing ring	5	Silencer

Spare parts	Part number	comprising the following parts
Overhaul kit	PU E22 001 -T	1, 2, 4 (complete)
Silencer	P 0920 567 E	5
Interhead connection	PK 050 267 -T	Complete unit

Tbl. 22: Spare parts

15 Accessories

15.1 Accessory information

Display and control units

Display and operating units are used to check and adjust operating parameters.

Power packs

Power packs for fastening to the wall and standard rails or for rack assembly serve the voltage supply.

Cable and adapter

Mains, interface, connection, and extension cables provide a secure and suitable connection. Different lengths on request

Connecting hoses

Connection hoses with adapters for connecting to a turbopump

Screw-In Flange

Screw-in flange incl. seal for the intake side of the vacuum pump

15.2 Ordering accessories

Selection field	Part number
TPS 110, power supply pack for wall/standard rail installation	PM 061 340 -T
TPS 111, power supply pack 19" plug-in unit 3HU	PM 061 344 -T
DCU 002, Display Control Unit	PM 061 348 AT
DCU 110, Display control unit with power supply pack	PM C01 820
HPU 001, Handheld Programming Unit	PM 051 510 -T
USB RS-485 converter	PM 061 207 -T
Y-distributor M12 to RS-485	P 4723 010
Connection cable MVP-TC-TPS, 3 m	PE 100 013 -T
Interface cable, M12 m straight/M12 m straight, 3 m	PM 061 283 -T
Connection cable with RS-485 interface for MVP to power supply pack	PM 061 350 -T
Connection cable for HiPace with TC 110/120	PM 061 543 -T
Hose connection DN 6 x 400 mm with straight connector 1/8" thread and 1/4" thread including seal	P 0920 739 E
Hose connection DN 6 x 1000 mm with straight connector 1/8" thread and 1/4" thread including seal	P 0920 817 E
Hose DN 6; (ø 8/6 mm) polyethylene	P 0991 939
Push-in fitting 1/8" thread including seal for hose connection (8/6 mm)	P 4131 029 G
Push-in T-fitting 1/8" thread	P 4131 030 E
Screwing flange DN 16 ISO-KF / 1/8" thread incl. seal	PK 050 108 -T

Tbl. 23: Accessories MVP 015-2 DC

16 Technical data and dimensions

16.1 General

Basis for the technical data of Pfeiffer Vacuum diaphragm pumps:

- Specifications according to PNEUROP committee PN5
- ISO 21360:2012: "Vacuum technology - Standard methods for measuring vacuum-pump performance - General description"

The following harmonized standards are fulfilled:

- IEC 61010-1
- UL 61010-1
- CSA 61010-1

	mbar	bar	Pa	hPa	kPa	Torr mm Hg
mbar	1	$1 \cdot 10^{-3}$	100	1	0.1	0.75
bar	1000	1	$1 \cdot 10^5$	1000	100	750
Pa	0.01	$1 \cdot 10^{-5}$	1	0.01	$1 \cdot 10^{-3}$	$7.5 \cdot 10^{-3}$
hPa	1	$1 \cdot 10^{-3}$	100	1	0.1	0.75
kPa	10	0.01	1000	10	1	7.5
Torr mm Hg	1.33	$1.33 \cdot 10^{-3}$	133.32	1.33	0.133	1

1 Pa = 1 N/m²

Tbl. 24: Conversion table: Pressure units

	mbar l/s	Pa m ³ /s	sccm	Torr l/s	atm cm ³ /s
mbar l/s	1	0.1	59.2	0.75	0.987
Pa m ³ /s	10	1	592	7.5	9.87
sccm	$1.69 \cdot 10^{-2}$	$1.69 \cdot 10^{-3}$	1	$1.27 \cdot 10^{-2}$	$1.67 \cdot 10^{-2}$
Torr l/s	1.33	0.133	78.9	1	1.32
atm cm ³ /s	1.01	0.101	59.8	0.76	1

Tbl. 25: Conversion table: Units for gas throughput

16.2 Technical data

Type designation	MVP 015-2 DC	MVP 015-2 DC
Part number	PK T05 150	PK T05 151
Number of pumping stages	2	2
Connection flange (in)	G 1/8"	G 1/8"
Connection flange (out)	1/8" thread with silencer	1/8" thread with silencer
Pumping speed, max.	1 m ³ /h	1 m ³ /h
Final pressure without gas ballast	3.5 hPa	3.5 hPa
Intake pressure max.	1100 hPa	1100 hPa
Exhaust pressure, max.	1100 hPa	1100 hPa
Gas ballast	Yes	Yes
Gas ballast pressure	≤ 1100 hPa	≤ 1100 hPa
Integral leakage rate	≤ $5 \cdot 10^{-4}$ Pa m ³ /s	$5 \cdot 10^{-4}$ Pa m ³ /s
Operating voltage: DC	24 V	24 V
Input voltage: tolerance	±10 %	±10 %
Rated current consumption	2.9 A	2.9 A
Current, max.	4.6 A	4.6 A

Type designation	MVP 015-2 DC	MVP 015-2 DC
Short circuit current of voltage source, max.	45 A	45 A
Rotation speed	540 – 2 600 rpm	540 – 2 600 rpm
Cooling method, standard	Convection cooled	Convection cooled
Operating altitude, max.	2000 m	2000 m
Protection degree	IP20	IP20
Ambient temperature	5 – 40 °C	5 – 40 °C
Temperature: Storage	5 – 40 °C	5 – 40 °C
Sound pressure level	50 dB(A)	50 dB(A)
Weight	2.7 kg	2.7 kg
I/O interfaces	RS-485	RS-485
Switch	No	No
Mains cable included	No	No
Mains cable	No	No

Tbl. 26: Technical data MVP 015-2 DC

16.3 Substances in contact with the media

Pump parts	Substances in contact with the media
Diaphragm	EPDM
Valves	EPDM
Head cover	Aluminium
Hose connection	PVC
Elbow union	Aluminium
Straight compression coupling on the intake flange	CuZn nickel-plated
Suction hose	Polyethylene
Exhaust, silencer	Polyamide

Tbl. 27: Materials that make contact with the process media

16.4 Dimensions

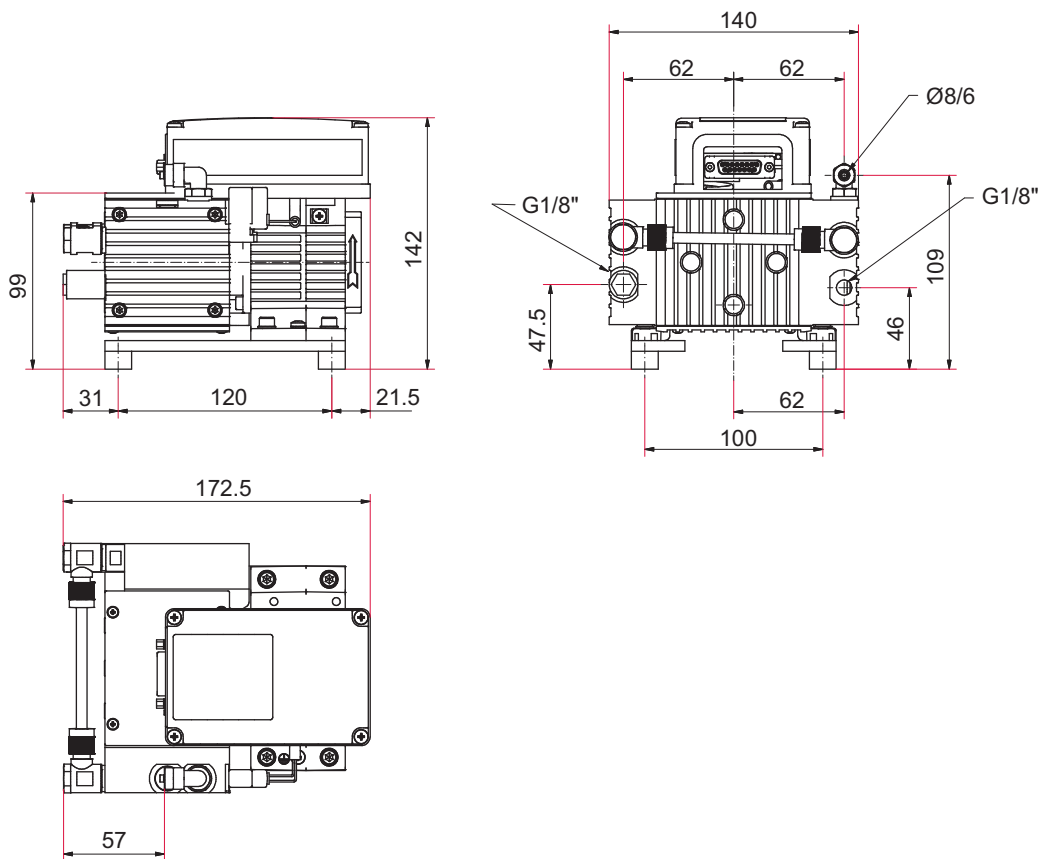

Fig. 12: Dimensions MVP 015-2 DC
Dimensions in mm

Declaration of conformity

Declaration for product(s) of the type:

Diaphragm pump

MVP 015-2 DC

We hereby declare that the listed product satisfies all relevant provisions of the following **European Directives**.

Machinery 2006/42/EC (Annex II, no. 1 A)

Electromagnetic compatibility 2014/30/EU

Restriction of the use of certain hazardous substances 2011/65/EU

Restriction of the use of certain hazardous substances, delegated directive 2015/863/EU

Harmonized standards and applied national standards and specifications:

DIN EN ISO 12100:2011

DIN EN 61000-6-2:2006 + Corr. 2011

DIN EN 1012-2:2011

DIN EN 61000-6-3:2007 + Corr. 2012

DIN EN 61010-1:2011

DIN EN IEC 63000:2019

DIN EN 61326-1:2013

The authorized representative for the compilation of technical documents is Mr. Wolfgang Bremer, Pfeiffer Vacuum GmbH, Berliner Straße 43, 35614 Asslar, Germany.

Signature:



(Daniel Sälzer)
Managing Director

Pfeiffer Vacuum GmbH
Berliner Straße 43
35614 Asslar
Germany

Asslar, 2020-06-09





VACUUM SOLUTIONS FROM A SINGLE SOURCE

Pfeiffer Vacuum stands for innovative and custom vacuum solutions worldwide, technological perfection, competent advice and reliable service.

COMPLETE RANGE OF PRODUCTS

From a single component to complex systems:

We are the only supplier of vacuum technology that provides a complete product portfolio.

COMPETENCE IN THEORY AND PRACTICE

Benefit from our know-how and our portfolio of training opportunities!

We support you with your plant layout and provide first-class on-site service worldwide.

ed. E - Date 2011 - P/N:PU0070BEN



Are you looking for a
perfect vacuum solution?
Please contact us

Pfeiffer Vacuum GmbH
Headquarters • Germany
T +49 6441 802-0
info@pfeiffer-vacuum.de

www.pfeiffer-vacuum.com

PFEIFFER  **VACUUM**